

# IR Components

2/9/18

R.B.Palmer

- Electron Magnets (10 GeV)
- Hadron Magnets (275 GeV)
- More on Special Magnets
- Vacuum
- Detectors

Note: Electron gradients and fields are given for 10 GeV electrons. Those for 18 GeV will not exactly scale from these numbers, although that would be a reasonable assumption for cost or practicality considerations.

# Electron Quads

Note: For Special Magnets in red see below for details

## Forward (10 GeV)

mag	rec	S m	L m	rad cm	grad T/m	Bpt T	
2	13	-215.5	0.6	2.0	-8.18	0.164	
3	25	-207.5	0.6	2.0	7.68	0.154	
4	31	-199.4	0.6	2.0	-10.43	0.209	
5	37	-191.4	0.6	2.0	8.79	0.176	
6	49	-183.3	0.6	2.0	-12.28	0.246	
7	59	-175.3	0.6	2.0	15.07	0.301	
8	65	-172.9	0.6	2.0	-15.77	0.315	
10	76	-167.2	0.6	2.0	30.32	0.606	
11	80	-166.1	0.6	2.0	-31.66	0.633	
12	84	-162.8	0.6	2.0	37.95	0.759	
13	88	-159.5	0.6	2.0	-31.66	0.633	
14	92	-158.3	0.6	2.0	30.32	0.606	
16	103	-152.7	0.6	2.0	0.59	0.012	
17	109	-145.1	0.6	2.0	-4.03	0.081	
18	115	-137.5	0.6	2.0	26.67	0.533	
19	119	-136.4	0.6	2.0	-16.89	0.338	
20	123	-135.2	0.6	2.0	-7.39	0.148	
21	129	-127.6	0.6	2.0	13.42	0.268	
22	135	-120.0	0.6	2.0	-6.32	0.126	
24	146	-107.8	0.6	2.0	26.11	0.522	
25	150	-106.7	0.6	2.0	-28.83	0.577	
26	154	-103.4	0.6	2.0	40.37	0.807	
27	158	-100.1	0.6	2.0	-28.83	0.577	
28	162	-98.9	0.6	2.0	26.11	0.522	
30	173	-86.8	0.6	2.0	4.16	0.083	
31	179	-79.1	0.6	2.0	-24.64	0.493	
32	183	-78.0	0.6	2.0	48.20	0.964	
33	187	-76.9	0.6	2.0	-24.64	0.493	
34	193	-69.3	0.6	2.0	30.21	0.604	
35	197	-67.8	0.6	2.0	-38.76	0.775	
36	201	-59.7	0.6	2.0	-16.98	0.340	
37	205	-51.6	0.6	4.0	5.66	0.226	
38	209	-43.5	0.6	4.0	-0.54	0.022	
39	214	-35.4	0.6	4.0	2.47	0.099	
40	217	-27.1	1.0	2.0	-5.79	0.116	
41	221	-9.	1.7	4.85	4.33	0.206	Q1Fe
42	225	-5.6	1.2	2.85	-9.63	0.274	Q0Fe

## Rear (10 GeV)

mag	rec	S m	L m	rad cm	grad T/m	Bpt T	
43	231	7.2	3.4	7.95	-2.81	0.22*	Q1Re
44	237	13.0	2.6	11.35	2.35	0.27*	Q2Re
45	243	31.5	0.7	4.0	-7.56	0.302	
46	251	43.6	0.4	4.0	0.92	0.037	
47	252	43.9	0.4	4.0	0.92	0.037	
48	256	51.8	0.4	4.0	5.03	0.201	
49	257	52.1	0.4	4.0	5.03	0.201	
50	263	60.3	0.7	2.0	-9.22	0.184	
51	269	67.8	0.6	2.0	30.37	0.607	
52	273	69.3	0.6	2.0	-27.73	0.555	
53	279	76.9	0.6	2.0	27.68	0.554	
54	283	78.0	0.6	2.0	-10.64	0.213	
55	287	79.2	0.6	2.0	-11.75	0.235	
56	293	86.8	0.6	2.0	5.24	0.105	
58	304	98.9	0.6	2.0	26.11	0.522	
59	308	100.1	0.6	2.0	-28.83	0.577	
60	312	103.4	0.6	2.0	40.37	0.807	
61	316	106.7	0.6	2.0	-28.83	0.577	
62	320	107.8	0.6	2.0	26.11	0.522	
64	331	120.0	0.6	2.0	-6.32	0.126	
65	337	127.6	0.6	2.0	13.42	0.268	
66	343	135.2	0.6	2.0	-7.39	0.148	
67	347	136.4	0.6	2.0	-16.89	0.338	
68	351	137.5	0.6	2.0	26.67	0.533	
69	357	145.1	0.6	2.0	-4.03	0.081	
70	363	152.7	0.6	2.0	0.59	0.012	
72	374	158.3	0.6	2.0	30.32	0.606	
73	378	159.5	0.6	2.0	-31.66	0.633	
74	382	162.8	0.6	2.0	37.95	0.759	
75	386	166.1	0.6	2.0	-31.66	0.633	
76	390	167.2	0.6	2.0	30.32	0.606	
78	401	172.9	0.6	2.0	-15.77	0.315	
79	407	175.3	0.6	2.0	15.07	0.301	
80	417	183.3	0.6	2.0	-12.28	0.246	
81	429	191.4	0.6	2.0	8.79	0.176	
82	435	199.4	0.6	2.0	-10.43	0.209	
83	441	207.5	0.6	2.0	7.68	0.154	
84	453	215.5	0.6	2.0	-8.18	0.164	

# Electron Quads Types (10 GeV)

Sorting by aperture:

number	req.	L	rad	grad	Bpt
		m	cm	T/m	T
63		0.6	2.0	50	1
8		0.6	4.0	10	0.4

The smaller magnets could also be sorted by required gradients  
Special (red) magnets not included in these counts

# Electron Dipoles (10 GeV)

Forward

mag	rec	S m	L m	rad cm	field(10) T	
1	5	-220.1	2.7	2.0	0.14	
2	7	-219.5	0.4	2.0	0.14	
3	9	-216.7	2.7	2.0	0.14	
4	17	-212.1	2.7	2.0	0.14	
5	19	-211.5	0.4	2.0	0.14	
6	21	-208.7	2.7	2.0	0.14	
7	41	-187.9	2.7	2.0	0.14	
8	43	-187.3	0.4	2.0	0.14	
9	45	-184.5	2.7	2.0	0.14	
10	53	-179.9	2.7	2.0	0.14	
11	55	-179.3	0.4	2.0	0.14	
12	57	-176.5	2.7	2.0	0.14	
13	63	-173.7	0.8	2.0	0.13	
14	107	-146.0	5.9	2.0	0.13	
15	113	-138.3	5.9	2.0	0.13	
16	127	-128.5	5.9	2.0	0.13	
17	133	-120.9	5.9	2.0	0.13	
18	177	-80.0	5.9	2.0	0.13	
19	191	-70.1	5.9	2.0	0.13	
20	235	11.2	1.9	5.7	-0.09	B1Re
21	241	19.2	4.0	5.4	-0.09	B2Re
22	247	37.3	5.2	4.0	0.10	
23	249	42.8	5.2	4.0	0.10	
24	267	66.1	5.2	2.0	-0.09	
25	277	76.0	5.9	2.0	0.13	
26	291	85.9	5.9	2.0	0.13	
27	335	126.8	5.9	2.0	0.13	
28	341	134.4	5.9	2.0	0.13	
29	355	144.3	5.9	2.0	0.13	
30	361	151.9	5.9	2.0	0.13	
31	405	174.5	0.8	2.0	0.13	
32	411	179.2	2.7	2.0	0.14	
33	413	179.7	0.4	2.0	0.14	
34	415	182.6	2.7	2.0	0.14	
35	423	187.2	2.7	2.0	0.14	
36	425	187.8	0.4	2.0	0.14	
37	427	190.6	2.7	2.0	0.14	
38	447	211.3	2.7	2.0	0.14	
39	449	211.9	0.4	2.0	0.14	
40	451	214.7	2.7	2.0	0.14	
41	459	219.4	2.7	2.0	0.14	
42	461	219.9	0.4	2.0	0.14	
43	463	222.8	2.7	2.0	0.14	

Rear

# Dipoles Types (10 GeV)

Sorting by length:

number	req.	Length m	Field T
16		2.659	.138
8		.4449	.138
2		.7642	.131
12		5.936	.131
1		1.89	.091
1		4	.091
3		5.2	.096

# Electron Sextupoles (10 GeV)

n	record	S m	L m	R cm	Strength T/m <sup>2</sup>
1	11	-216.0	0.500	2.0	-76.59
2	23	-208.0	0.500	2.0	49.80
3	29	-199.9	0.500	2.0	-76.59
4	35	-191.9	0.500	2.0	49.80
5	47	-183.8	0.500	2.0	-76.59
6	421	184.3	0.500	2.0	-76.59
7	433	192.4	0.500	2.0	49.80
8	439	200.4	0.500	2.0	-76.59
9	445	208.5	0.500	2.0	49.80
10	457	216.5	0.500	2.0	-76.59

Just one type, 10 magnets, each 50 cm long and 2 cm aperture

# Electron Solenoids (10 GeV)

mag	rec	S	L	rad	Strength(10)
		m	m	cm	T/m <sup>2</sup>
1	74	-167.9	2.7	2.0	3.77
2	96	-154.9	2.7	2.0	3.77
3	144	-108.7	9.0	2.0	3.55
4	166	-89.1	9.0	2.0	3.55
5	302	98.1	9.0	2.0	3.55
6	324	117.7	9.0	2.0	3.55
7	372	157.6	2.7	2.0	3.77
8	394	170.6	2.7	2.0	3.77

Just 2 types required with lengths 2.7 and 9 m long, all with 2 cm aperture

# Rear Hadron Magnets (275 GeV)

I	S m	L m	Ap cm	Grad T/m	Bpt T	BBB T	
4	-152.345	2.949	4.00			3.779	DH9Rp
9	-141.694	1.110	4.00	83.180	3.33		QF9Rp
15	-134.297	9.441	4.00			3.779	DH8Rp
21	-126.900	1.110	4.00	-105.556	-4.22		QD8Rp
25	-119.495	0.930	4.00	41.990	1.68		QF7ARp
29	-112.644	1.859	4.00	75.239	3.01		QF7Rp
35	-108.115	2.949	4.00			3.779	DH6Rp
38	-99.074	9.100	4.00			3.922	B3Rp
40	-93.024	1.000	4.00	-87.260	-3.49		Q7Rp
42	-77.023	1.000	4.92	43.222	2.13		Q6ARp
44	-69.523	1.000	4.92	0.041	0.00		Q6Rp
46	-61.523	1.000	4.74	67.259	3.19		Q5Rp
48	-54.023	1.000	4.00	-68.296	-2.73		Q5ARp
50	-48.978	5.690	4.00			-4.633	B2Rp
54	-20.708	1.200	4.00	49.635	1.99		Q3Rp
58	-12.932	2.570	4.00	45.475	1.82		Q2Rp
60	-8.185	3.420	4.00	-67.084	-2.68		Q1Rp

# Forward Hadron Magnets (275 GeV)

I	S m	L m	A3 cm	Grad T/m	Bpt T	BBB T	
68	5.600	1.200	17.00			-1.299	B0Fp
71	6.800	1.500	4.20	-132.649	-5.57		Q1Fp
73	11.002	2.400	10.50	47.223	4.96		Q2Fp
75	17.904	3.000	13.50			-4.571	B1Fp
77	30.004	1.200	4.00			1.353	B2AFp
79	35.004	7.800	4.00			3.911	B2BFp
81	39.404	1.200	4.00	-29.638	-1.19		Q3AFp
83	46.904	1.200	4.92	26.151	1.29		Q3Fp
85	53.204	2.400	4.92	93.584	4.61		Q4LFp
221	59.504	3.600	4.00	99.172	3.97		Q4ALFp
224	68.567	8.800	4.00			3.645	B3Fp
227	74.765	1.200	4.00	-95.998	-3.84		NQFp
229	81.977	1.000	4.00	51.802	2.07		Q5AFp
231	88.977	1.000	4.00	22.108	0.88		Q5Fp
235	99.737	1.000	4.00	37.416	1.50		Q6AFp
237	102.041	1.000	4.00	-86.260	-3.45		Q6BFp
239	104.546	1.000	4.00	9.452	0.38		Q6CFp
242	108.196	2.949	4.00			3.779	DH6Fp
248	111.801	1.859	4.00	-77.423	-3.10		Q7Fp
256	126.987	1.110	4.00	83.047	3.32		Q8Fp
262	134.401	9.441	4.00			3.779	DH8Fp
268	141.815	1.110	4.00	-87.280	-3.49		Q9Fp
281	152.472	2.949	4.00			3.779	DH9Fp



# Special Magnets (red in the above lists)

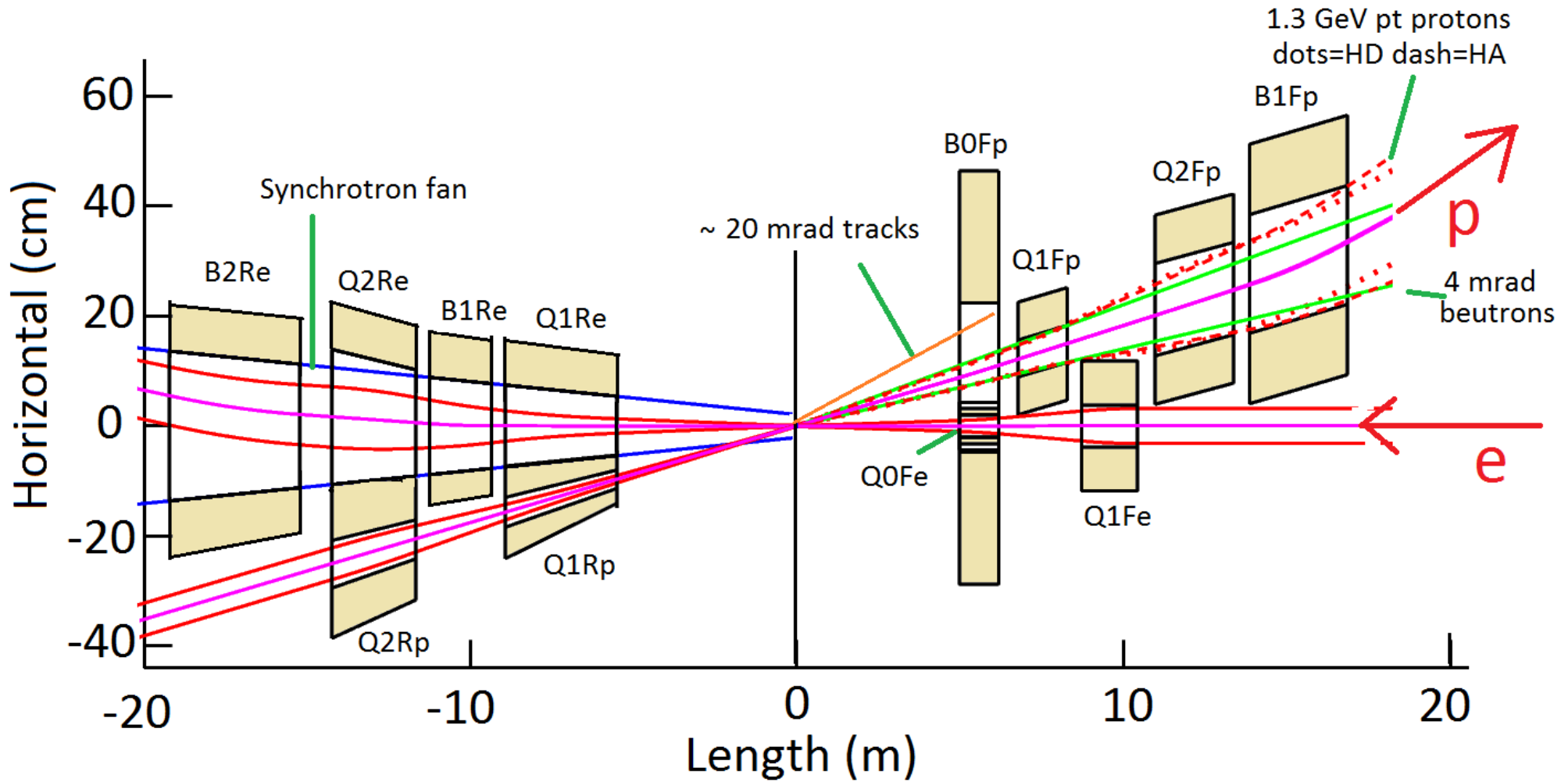

## Special challenges

- Hadron and electron beams are very close
- Need independent strong focusing
- Highly suppressed dipole fields on electrons against synchrotron
- In two cases apertures especially large:
  - Forward hadron acceptance for 5 mrad low pt tracks
  - Rear electron beam to avoid intersecting synchrotron

# Forward Magnets

## Forward Hadron (275) GeV

	L1	DL	gap	x	$\theta$	IR	Bpt	B	Grad)
	m	m	m	cm	mrاد	cm	T	T	T/m
B0Fp	3	5.00	1.20	0.60	11.0	0.00	17.00	1.299	
Q1Fp	5	6.80	1.50	2.70	15.4	22.00	4.20	5.57	-132.649
Q2Fp	7	11.00	2.40	0.50	26.4	20.00	10.50	4.96	47.223
B1Fp	9	13.90	3.00	20.90	34.6	22.00	13.50	4.571	

## Forward Electron (18)

Gradients from Guillaume multiplied by 1.8 for 18 GeV/c

	L1	DL	gap	x	$\theta$	IR	Bpt	Grad)	
	m	m	m	cm	mrاد	cm	T	T/m	
Q0Fe	3	5.00	1.20	2.54	0.0	0.00	2.85	0.494	-17.33
Q1Fe	5	8.74	1.72	7.02	0.0	0.00	5.00	0.376	7.79

## 0.1 Forward Spectrometer (B0pF)

The spectrometer magnet in the forward hadron beam is a 1.3 T bending magnet that contributes to the dog leg that takes the beam clear of the forward neutron detector. Width 50 cm, height 23 cm length 1.2 m, warm iron, cold coils.

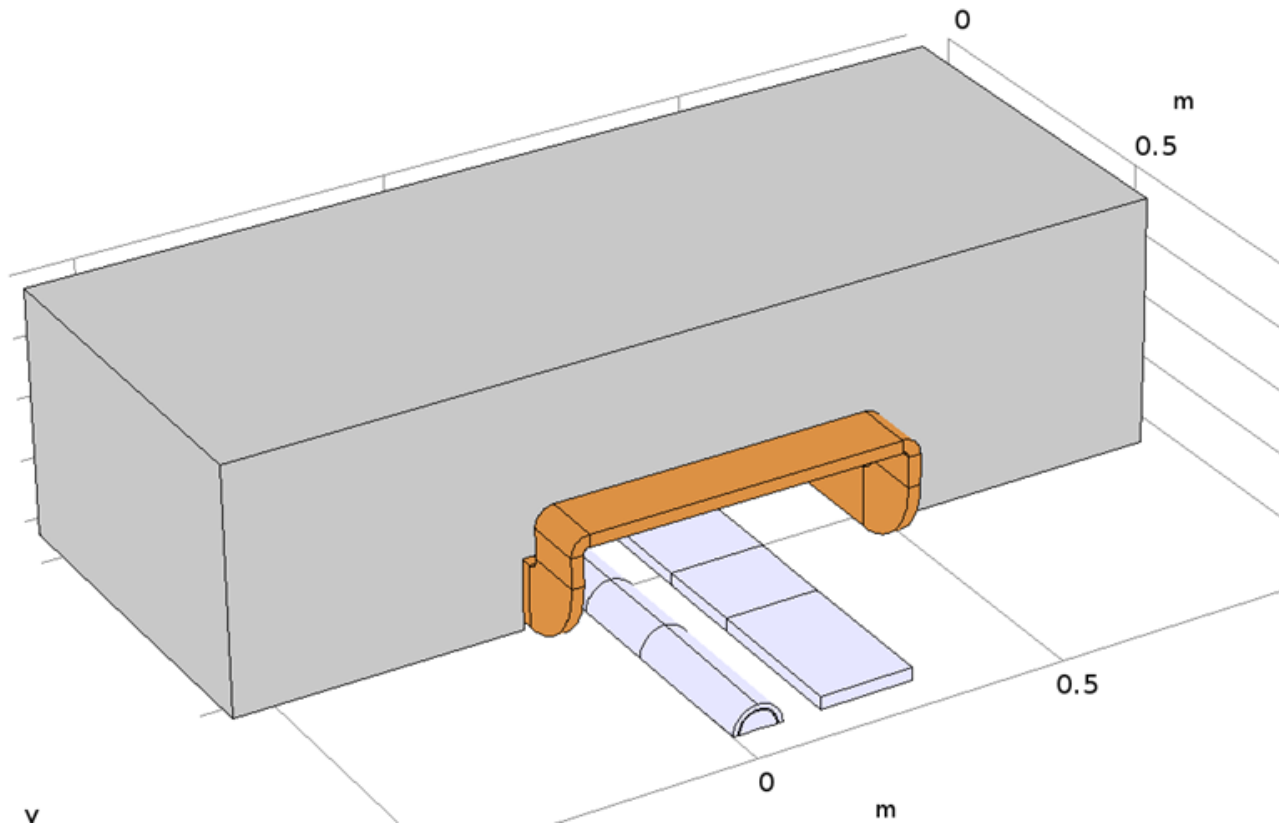

# Forward first electron Quad

Being inside the 1.3 T spectrometer, this magnet needs active shielding

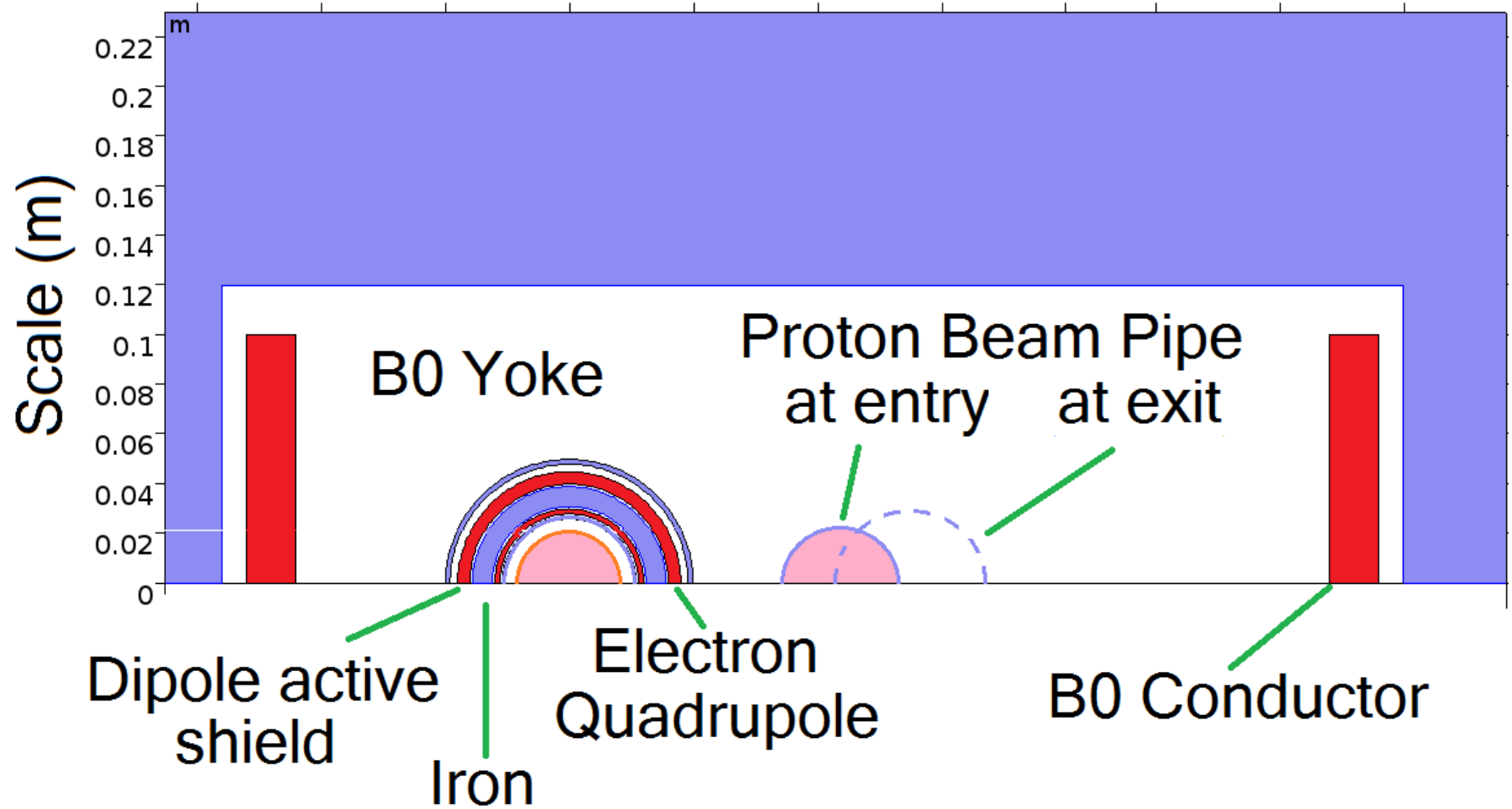

# Detail of Q0Fe and its active shield

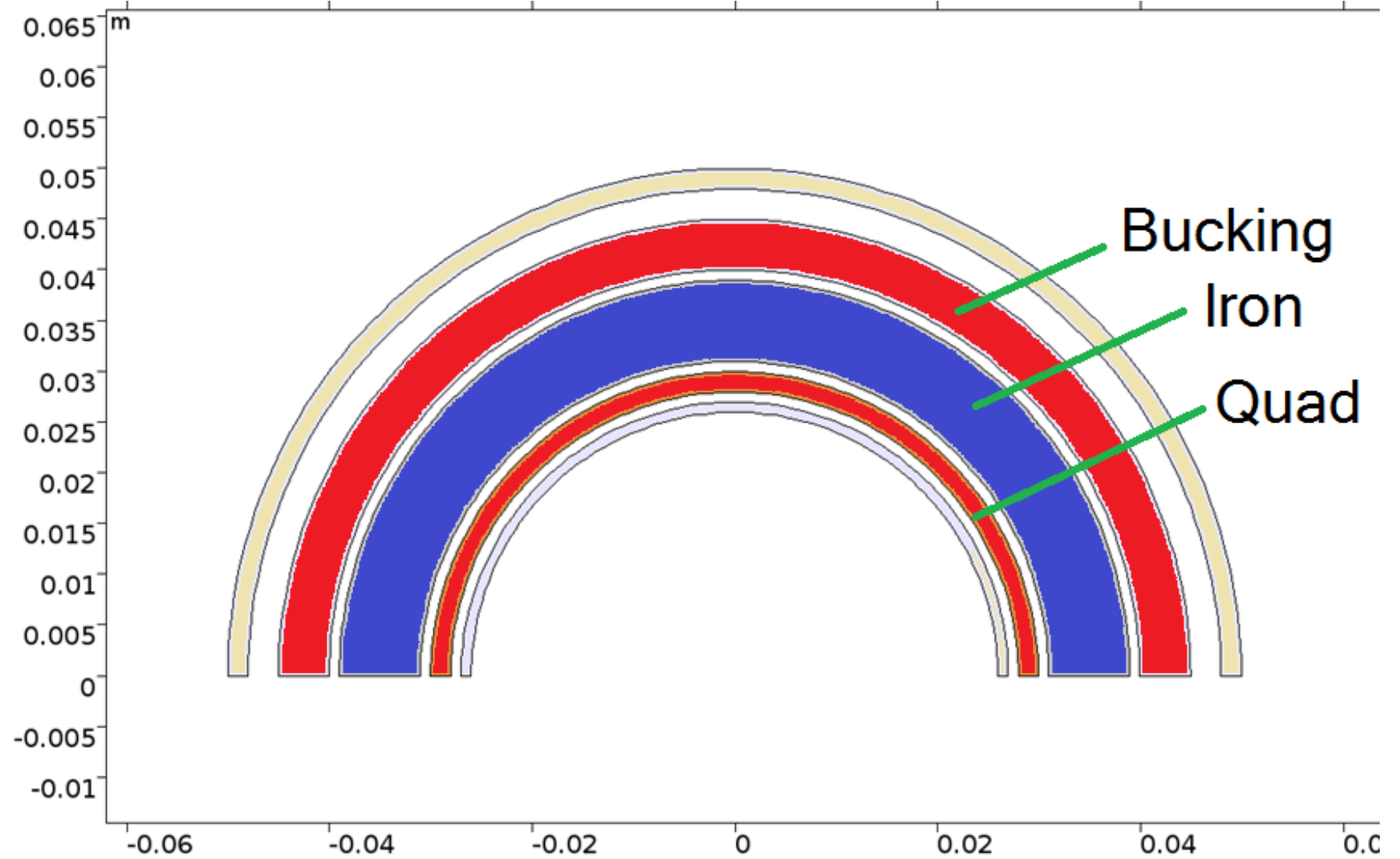

# First forward hadron quadrupole Q1Fp

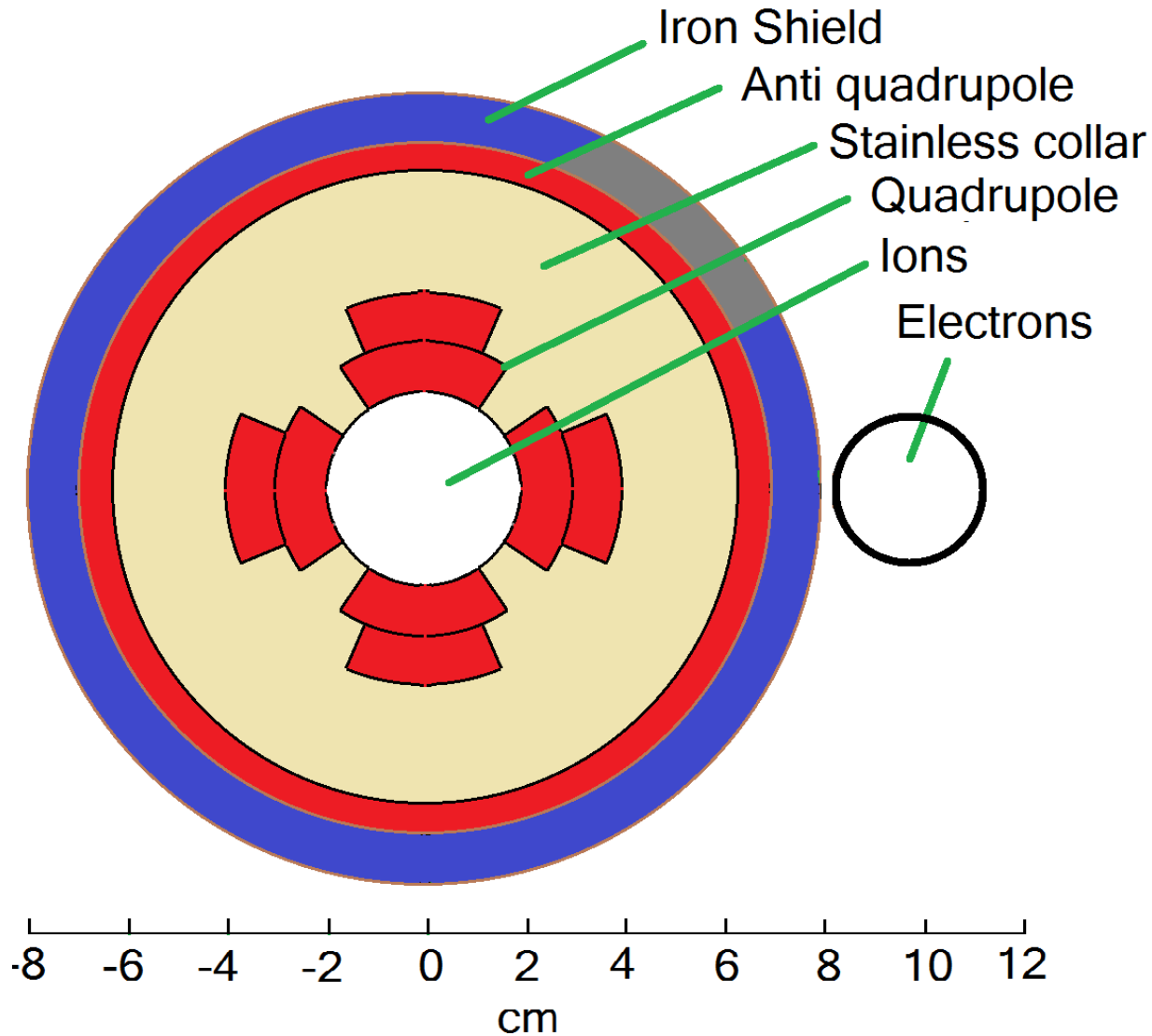

- High fields in this magnet require Nb<sub>3</sub>Sn or 1.8 deg K

## 0.2 Second Forward Hadron quad Q2Fp

Could use active shielding as in Q1pF, or :

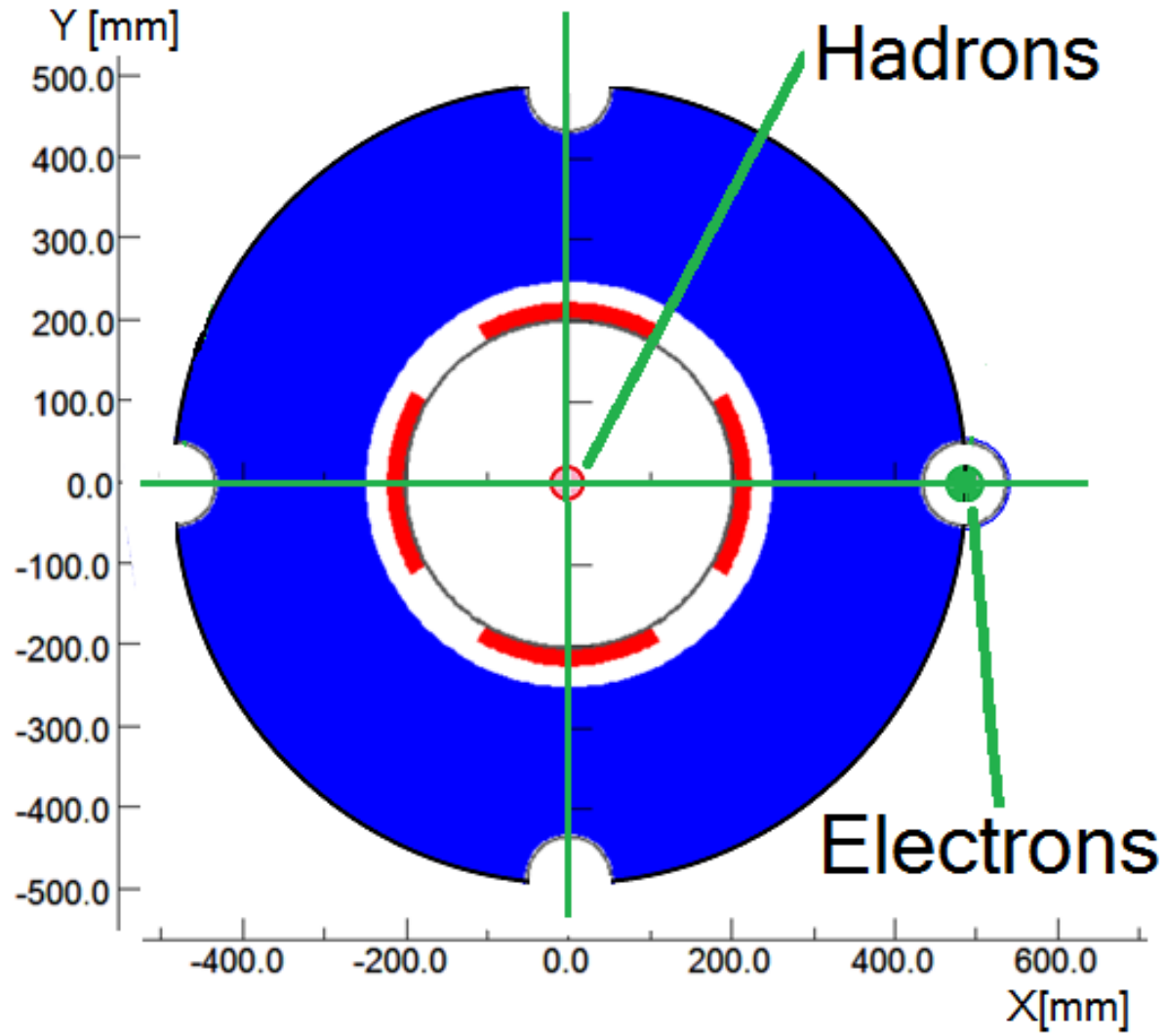



## Rear Magnets      Rear hadron (275)

Magnets are tapered in proportion to their distance to the IP

	L1	DL	gap	x	$\theta$	IR <sub>1</sub>	IR <sub>2</sub>	B	Grad)	
	m	m	m	cm	mrاد	cm	cm	T	T/m	
Q1Rp	3	5.50	3.42	2.75	-12.1	-22.00	2.09	3.39	1.40-2.29	-67.08
Q2Rp	5	11.67	2.57	2.69	-25.8	-22.00	4.50	5.49	2.05-2.50	45.48

## Rear Electrons (18)

Magnets are tapered to follow the estimated (see following slide) horizontal synchrotron fan from electrons at 15 sigma given by:

$$x_{synch} \approx 0.64(|L(m)| + 3.5) \quad (cm)$$

	L1	DL	gap	x	$\theta$	IR <sub>1</sub>	IR <sub>2</sub>	B	Bpt	Grad)
	m	m	m	cm	mrاد	cm	cm	T	T	T/m
Q1Re	3	5.50	3.42	2.75	2.8	-7.30	5.76	7.95	0.29-0.40	-5.06
B1Re	20	11.2	1.9					-0.09		
Q2Re	7	11.67	2.57	0.37	3.5	10.00	0.71	11.35	.41-.48	4.23
B2Re	21	19.2	4.0					-0.09		

# Recent Re-estimation of synchrotron Fan

Beam and fan for 15 sigma beam.

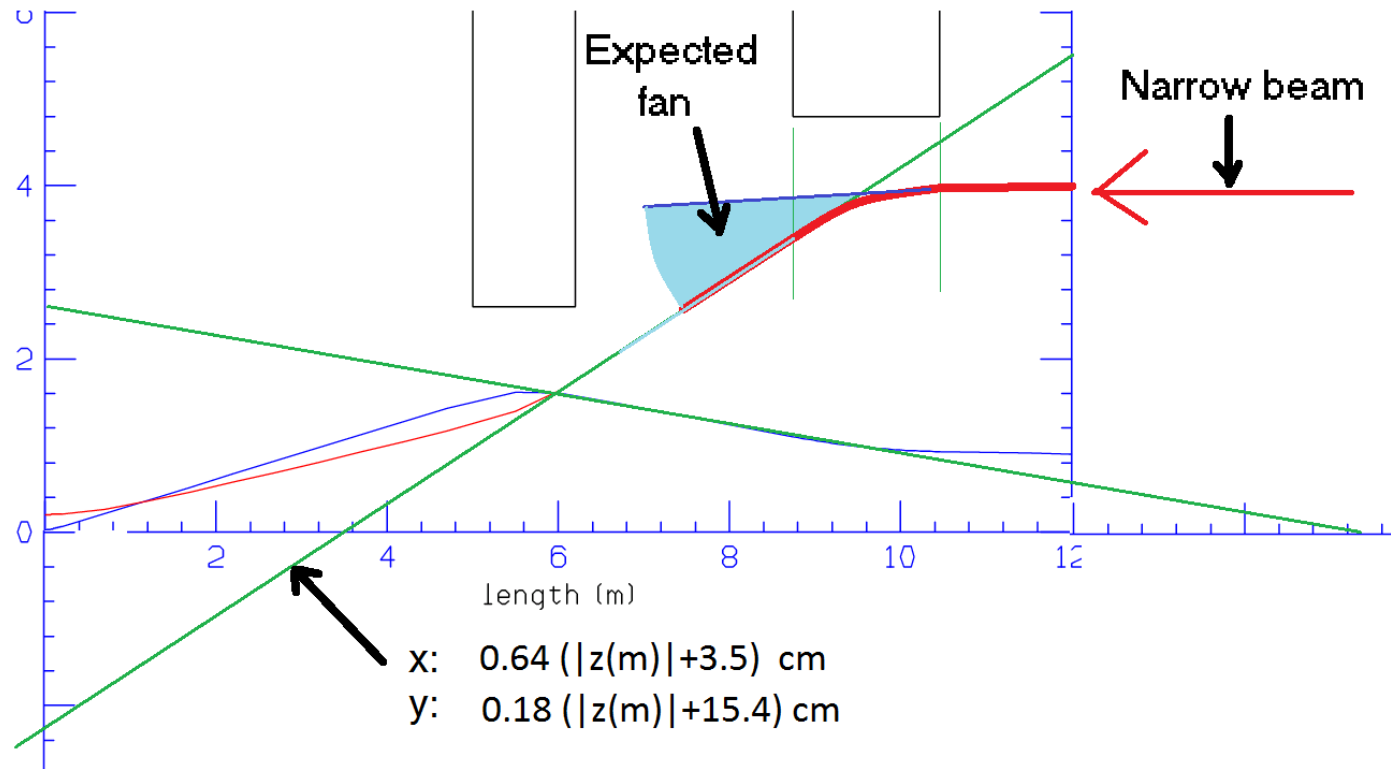

My re-estimation got a somewhat narrower fan, and Charlie Hetzel, running a CERN program got an even narrower fan. This is still under study.

# Q1Re and Q1Rp

The hadron and electron gradients must be independently set, requiring iron between them. To maximize the space for iron between them, the beam pipes and quadrupoles are tapered, following the synchrotron fan in the electron case, and the diverging beam of the protons.

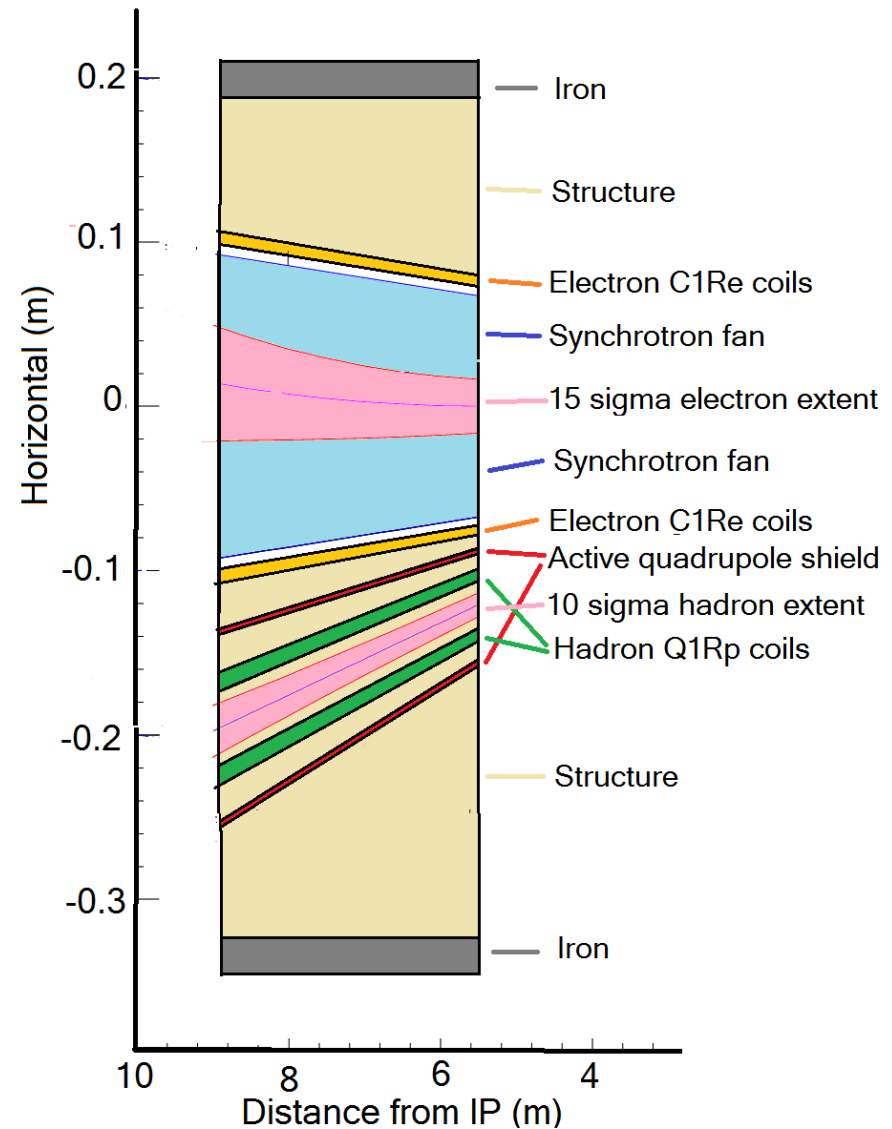

# Q1Re and Q1Rp continued

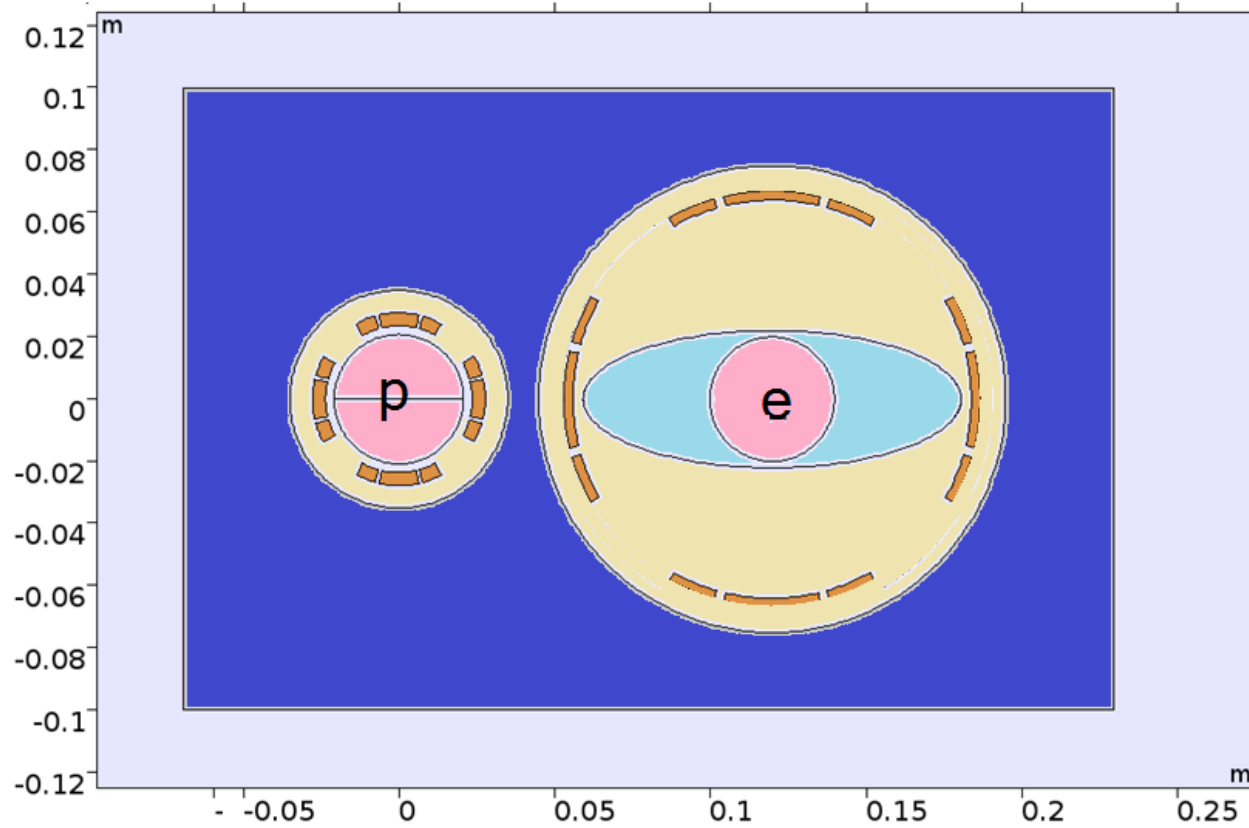

## 0.3 Second Quads: Q2Re & Q2Rp

Could be similar to C1 but with more space between beams, it may not need to be tapered

# Vacuum Concept (C. Hetzel)

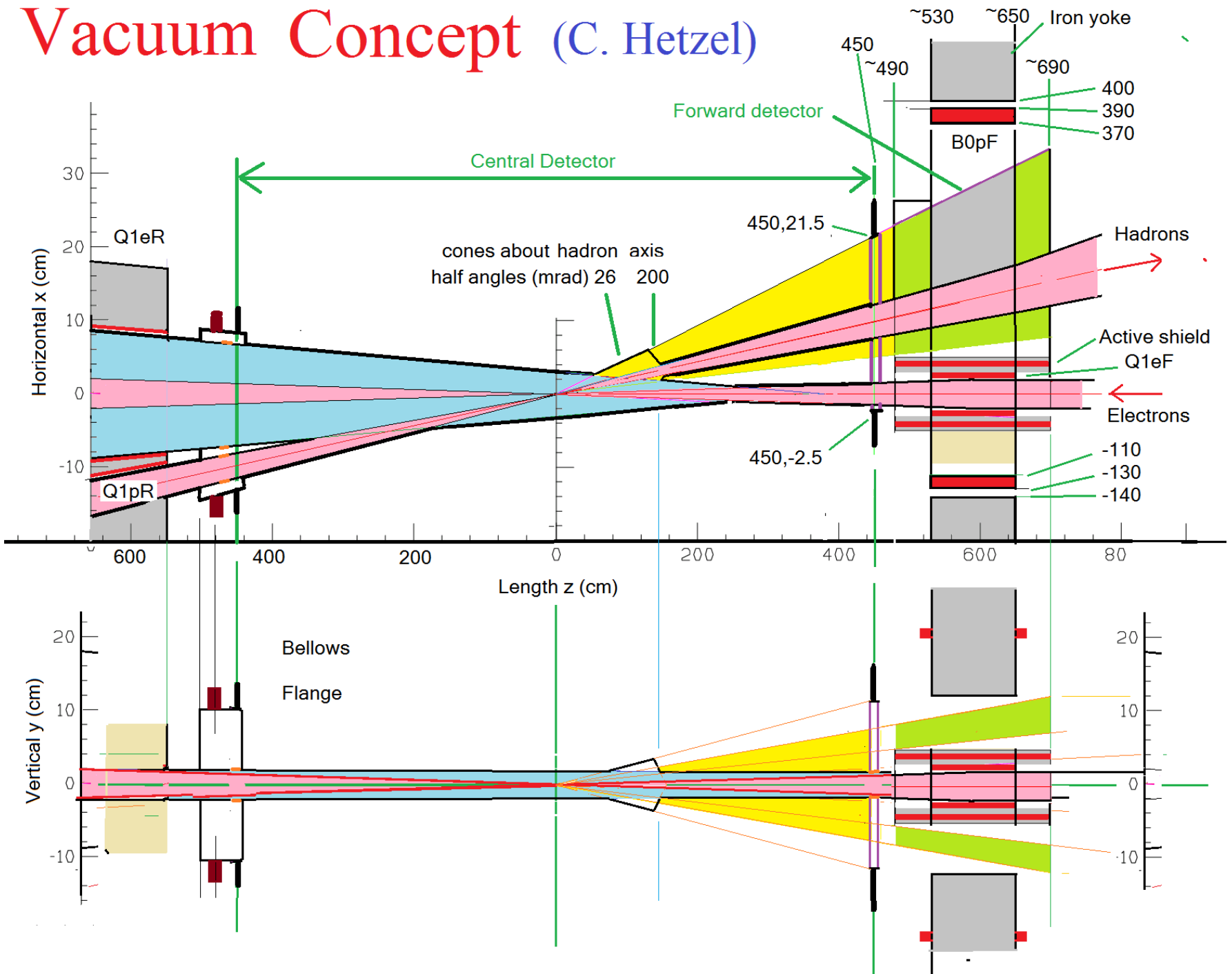

d

# Concept of Rear Flange & Bellows (Charlie Hetzel)

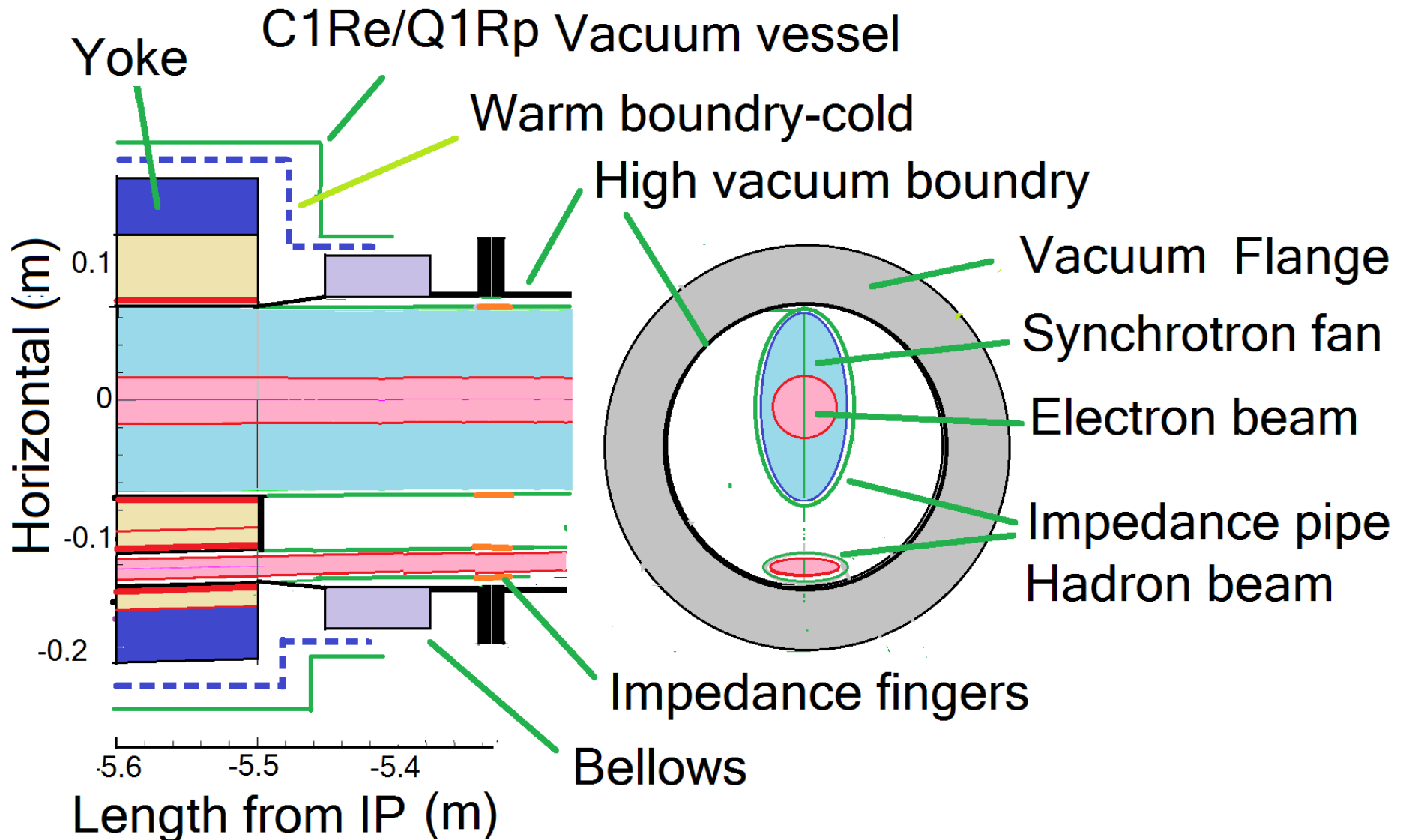

# Forward Flange & Bellows

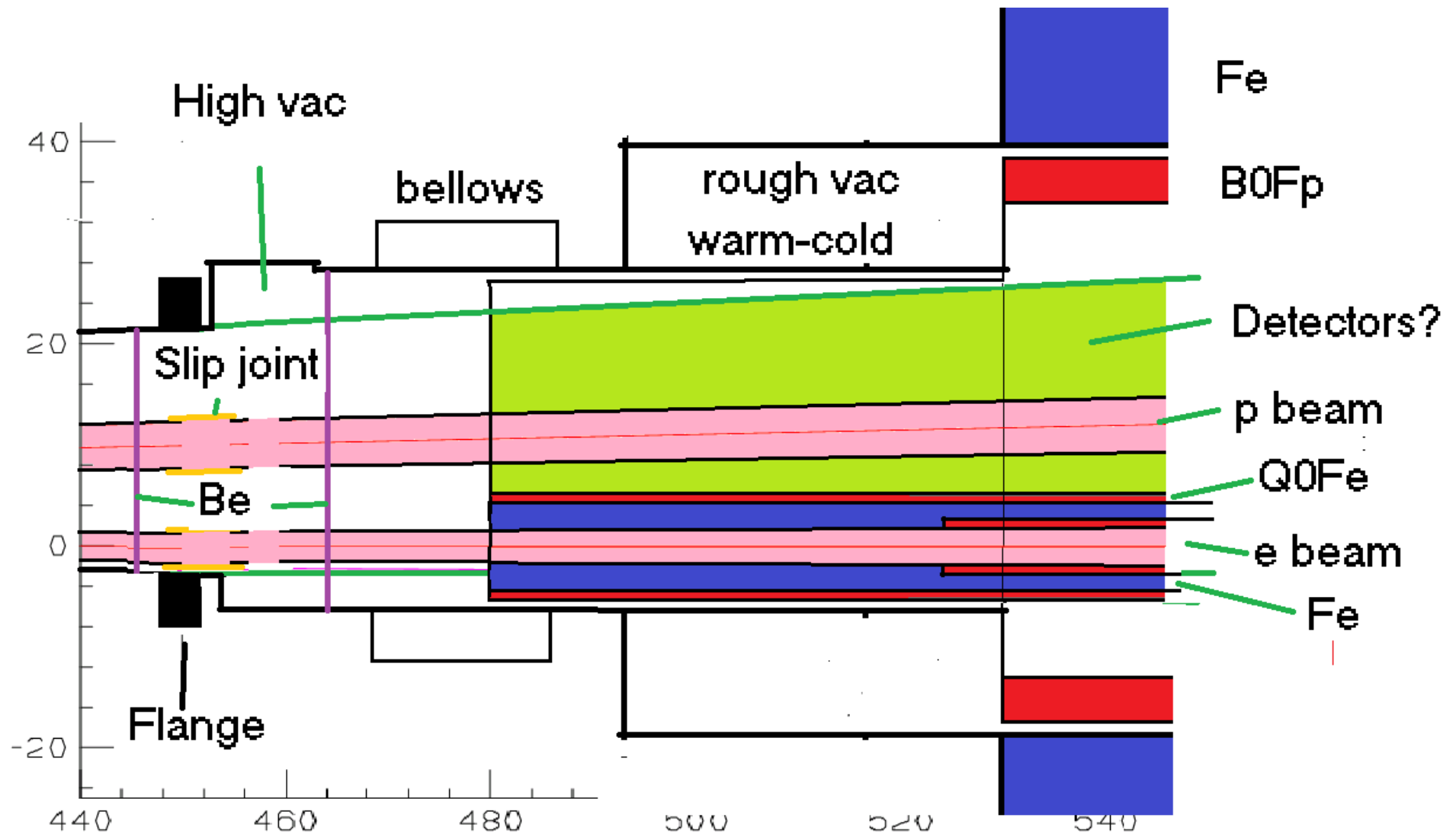

# 1 Detectors

## 1.1 Forward Spectrometer

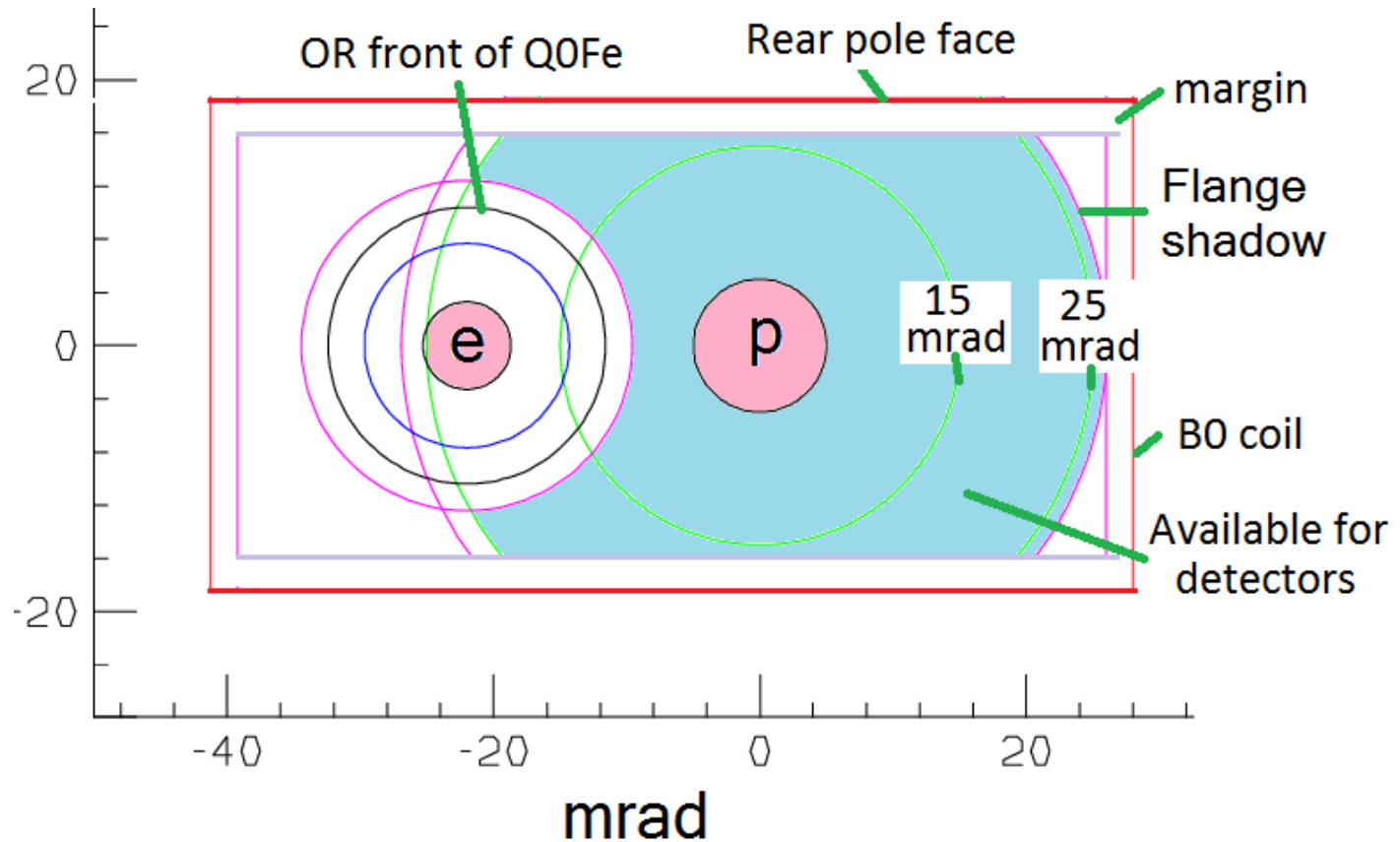

Blue shows angular range over which detectors could, in principle, be located just before, in & just after the Forward spectrometer



## 1.2 Other Forward Detectors

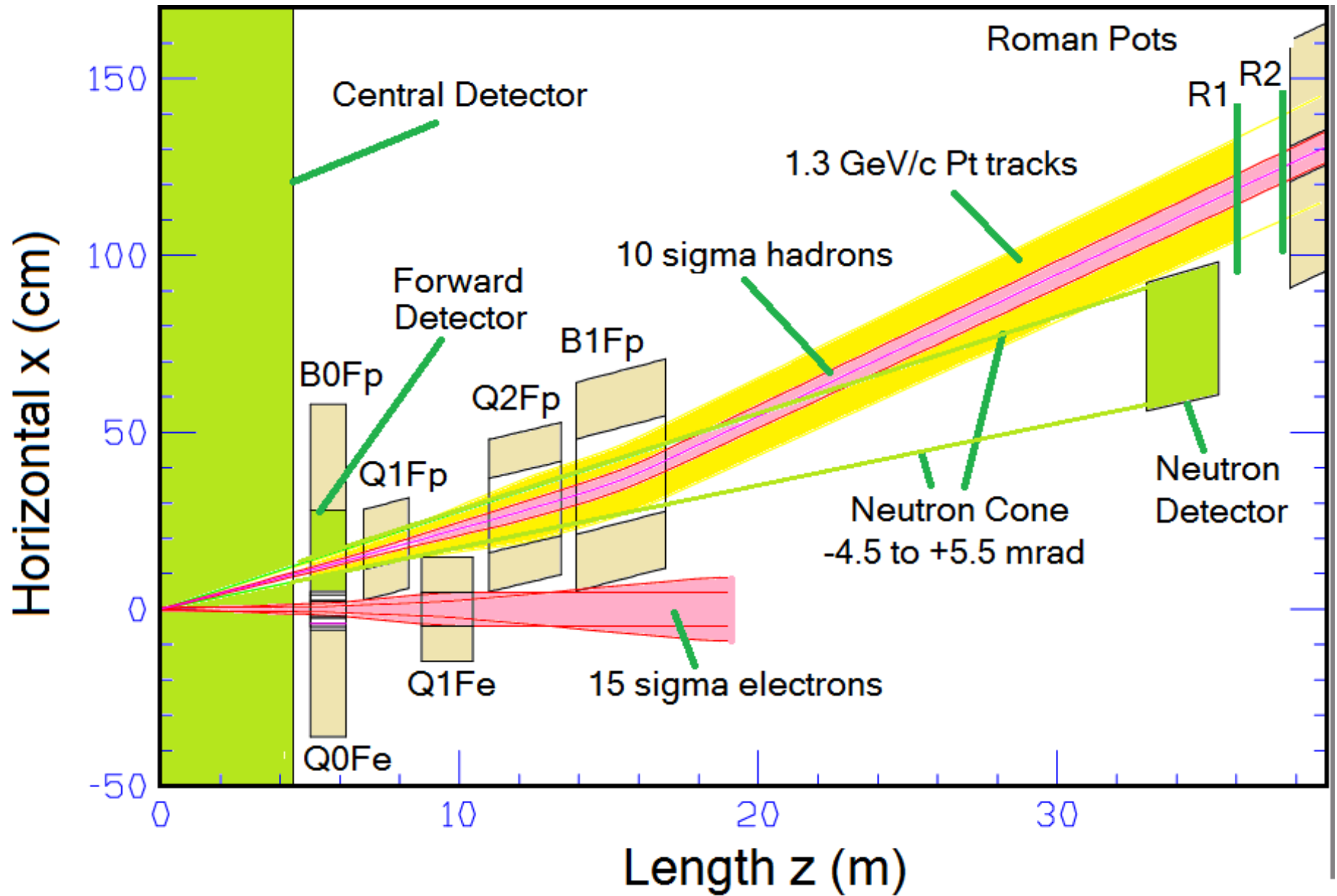

# Rear Side & Detectors

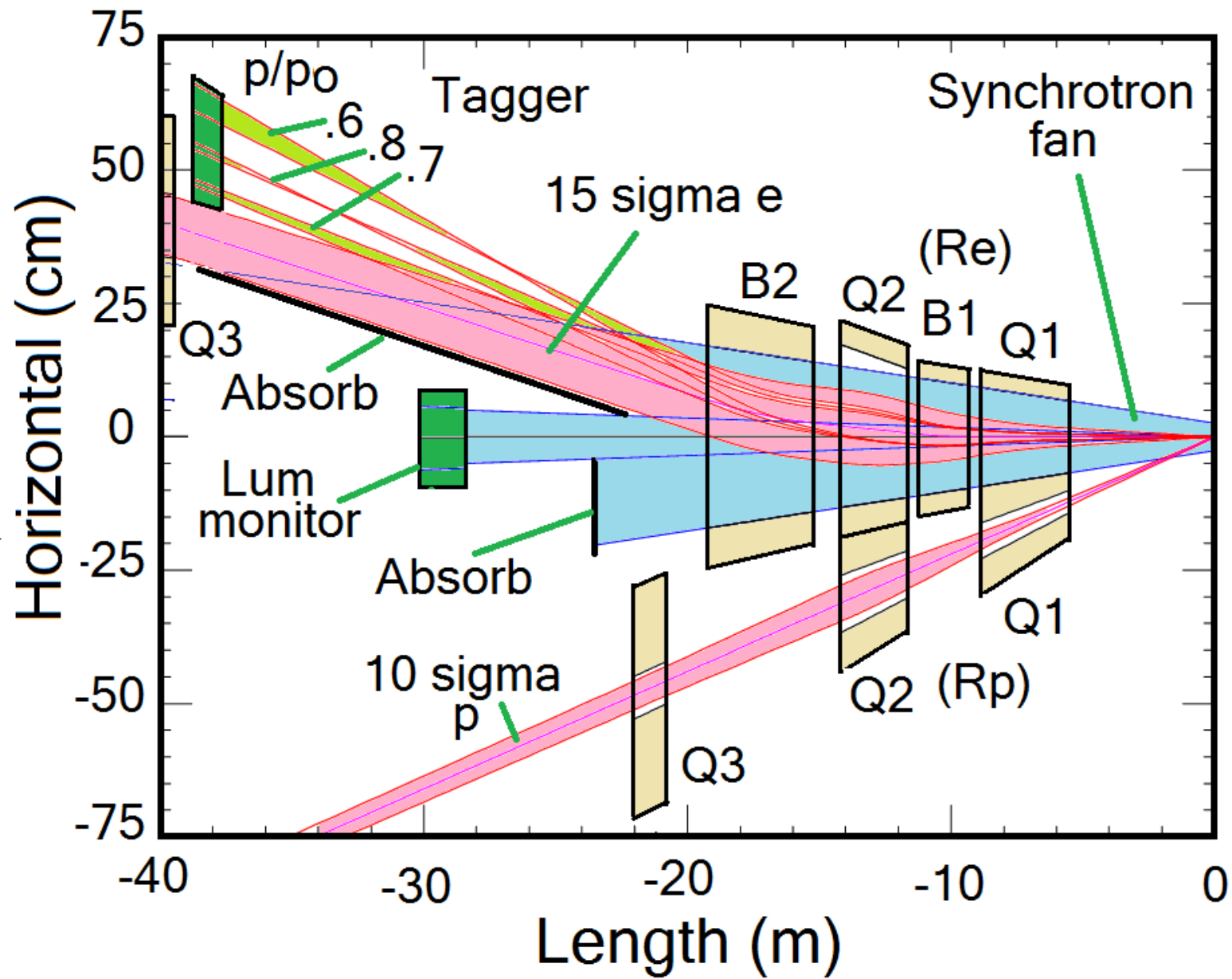

# Tagger and Luminosity Monitor

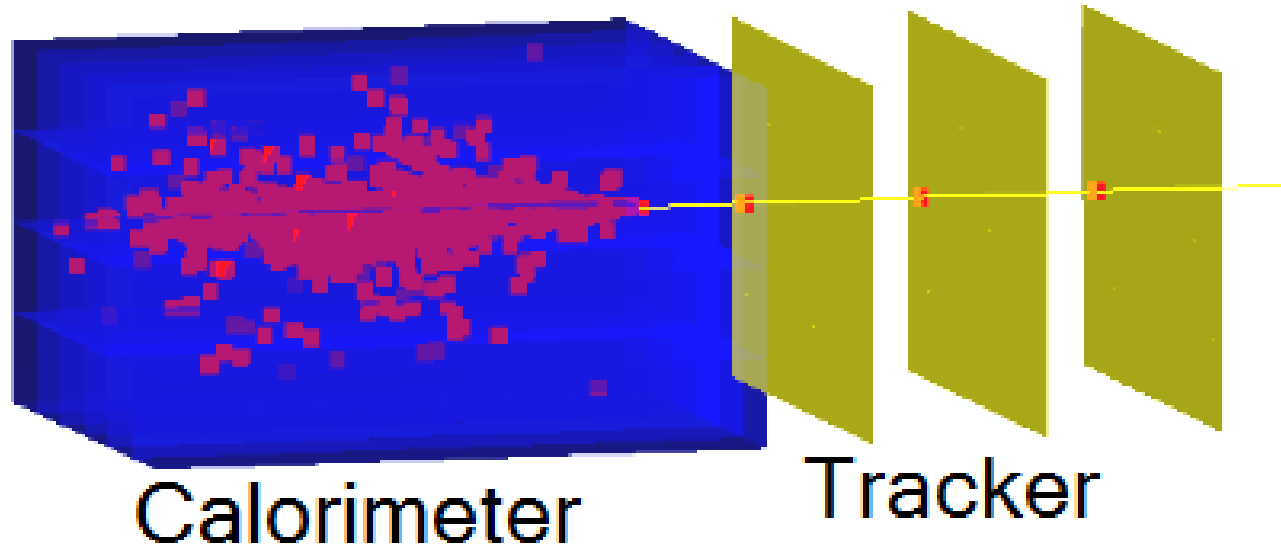

Detects small angle outgoing electrons with momenta between 85% and 50% of beam electrons

Luminosity monitor observes photons emitted within 5 sigma of the electron beam divergence