

Validation of Production SiPMs for the sPHENIX Experiment

N. Grau

Augustana University for the sPHENIX Collaboration

October 17, 2019



sPHENIX Experiment

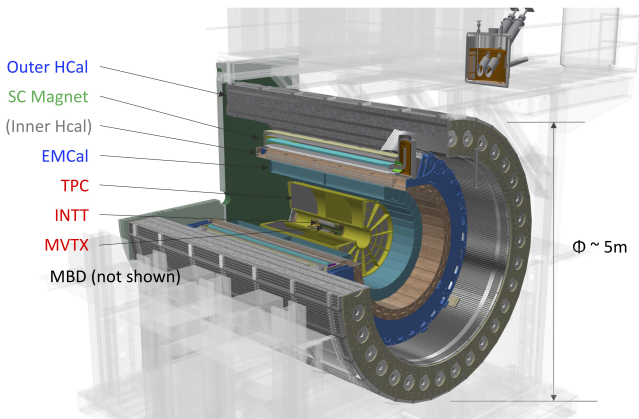

- ▶ A new detector at RHIC
- ▶ Microscopic properties of the QGP from
 - ▶ jets
 - ▶ direct photons
 - ▶ heavy flavors



Electromagnetic and Hadronic Calorimeter

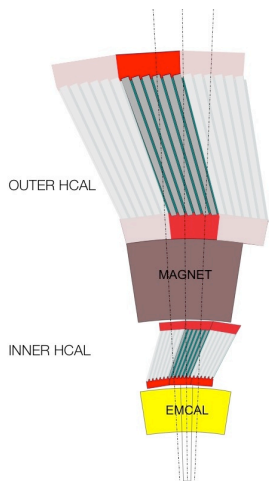

- ▶ Electromagnetic Calorimeter: Scintillating fibers embedded in W powder
 - ▶ $\Delta\eta \times \Delta\phi = 0.024 \times 0.024$
 - ▶ $\sigma_E/E = 16\%/\sqrt{E} \oplus 5\%$
- ▶ Hadronic Calorimeter: Plastic scintillating tiles + tilted Steel/Al plates
 - ▶ $\Delta\eta \times \Delta\phi = 0.1 \times 0.1$
 - ▶ $\sigma_E/E = 100\%/\sqrt{E}$
- ▶ Common readout via SiPMs (e.g. 4 per EMCal Tower): 106,000 total devices

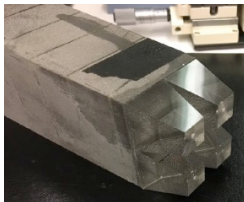

Hamamatsu S12572-015P SiPMs

Photosensitive Area	$3 \times 3 \text{ mm}^2$
Pixel pitch	$15 \text{ }\mu\text{m}$
# of pixels	40000
peak wavelength sensitivity	460 nm
photon detection efficiency	25%
Gain	2.3×10^5
Operating voltage	$\approx V_{br} + 4 \text{ V}$
Voltage-Temperature Slope	$56 \text{ mV}/^\circ\text{C}$

- ▶ Immune to magnetic fields
- ▶ Susceptible to radiation damage

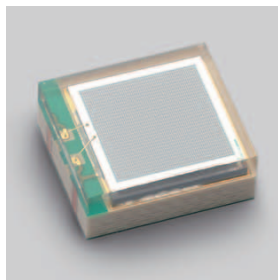

Shipment Schedule

- ▶ 8000 devices shipped monthly to University of Michigan for testing
- ▶ Trays of full 12x13 or partial trays in 40 mV bins of operating voltage



Test Stand

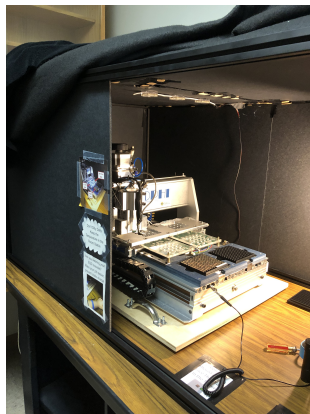
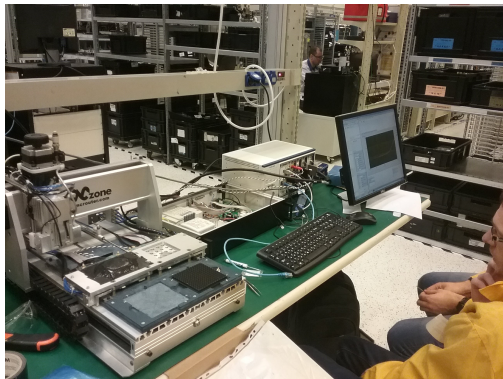

- ▶ Developed by University of Debrecen
- ▶ Testing at University of Michigan
- ▶ Perform both I-V and Single Pixel Spectrum (SPS) tests



Test Stand

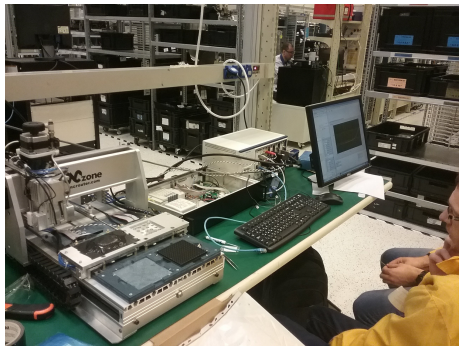

- ▶ Rough I-V scan to estimate V_{br} .
- ▶ LED pulses at 6 different V_{op} for SPS

- ▶ Motorized arm with micron precision and vacuum nozzle moves SiPMs from tray to test position
- ▶ Electrical connections by weight and pressure
- ▶ National Instruments crate for high voltage and data acquisition
- ▶ 50 temperature sensors with 0.1°C precision



I-V Scan

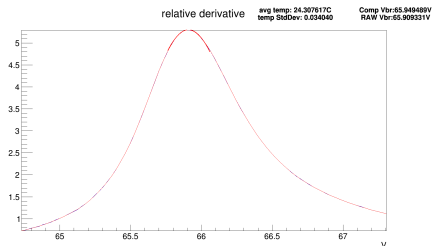
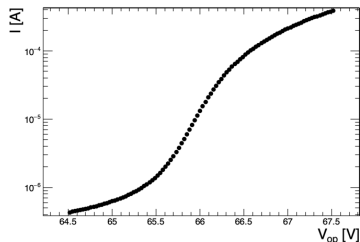

- ▶ Example I-V scan for single SiPM
- ▶ Measure current draw for low intensity DC LED light
- ▶ $d(\ln(I))/dV$ maximum at V_{br}
- ▶ Use measured temperature to correct to 25° C



Single Pixel Spectrum

- ▶ 100,000 LED pulses at 6 different V_{op}
- ▶ GHz digitizer produces output signal that is integrated and histogrammed

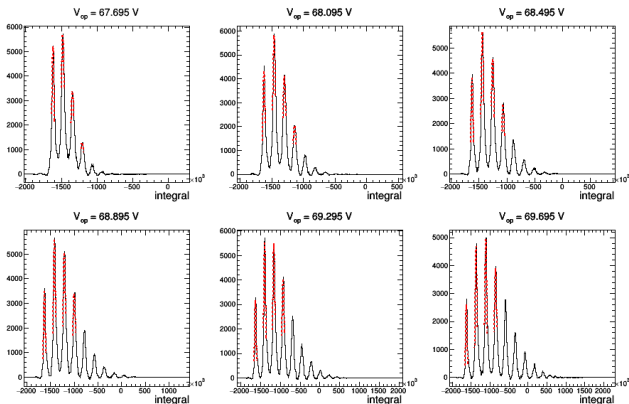

Single Pixel Spectrum

- ▶ Relative gain is determined by the peak-to-peak differences in SPS
- ▶ Linear relationship between relative gain and V_{op} .
- ▶ Uncertainties are smaller than the points.

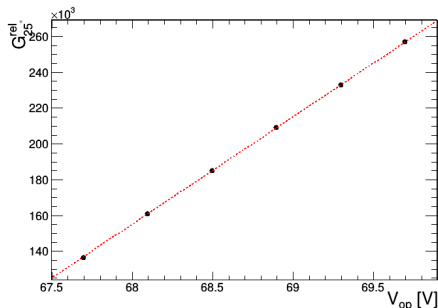

Testing To Date

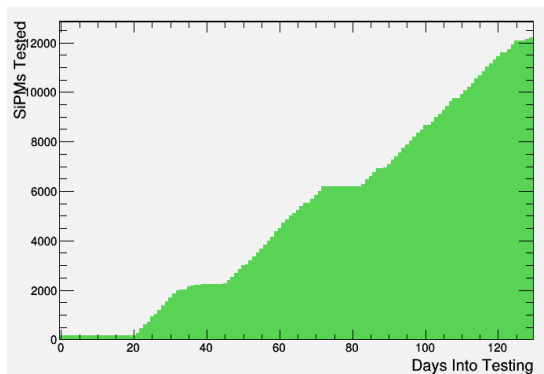

- ▶ We can test approximately 1 tray (156 SiPMs) per day
- ▶ First delivery in March 2019
- ▶ 8000 SiPMs delivered/month



Correlation With Hamamatsu

- ▶ Correlations of Our V_{br} at 25°C compared to mean tray V_{op}
- ▶ Each color a different monthly shipment

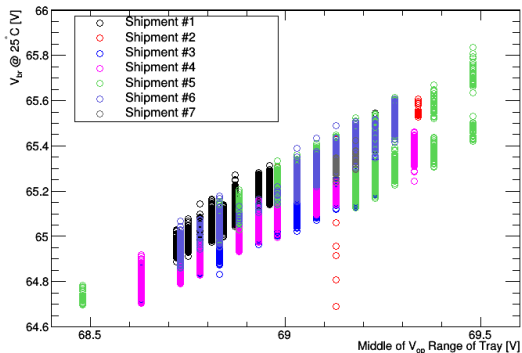

Slope Distributions

- ▶ Bimodal slope distribution possibly due to differences between wafers.

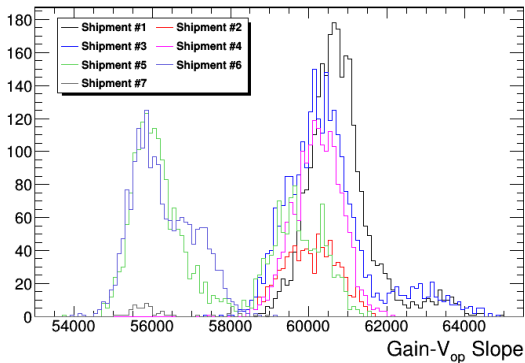

Effect on Calorimeter Energy Resolution

- ▶ Toy simulation of effect of randomly combining 4 SiPMs from a single tray
- ▶ Vary tray σ_G/G
- ▶ Gain variations contribute to the constant term in energy resolution
- ▶ $\sigma_G/G \sim 2\%$, $\sigma_E/E \ll 1\%$

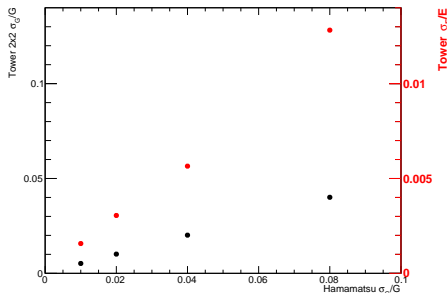

Summary

- ▶ sPHENIX has ordered and are receiving shipments of 106,000 Hamamatsu SiPMs for calorimeter readout.
- ▶ Test stand up and running.
- ▶ Small relative width of the tray gain distribution results in very small addition to constant term in the energy resolution.

