

NOTES:

1. ALL DIMENSIONS ARE IN in[mm].
2. FOR MATERIAL SPECIFICATIONS REFER TO CURRENT REVISION OF DOCUMENT SP-DS-OHC-001 SECTION 3.1

REVISION HISTORY					
REV	ECN NUMBER	ZONE	DESCRIPTION	DATE	APPROVED
A			INITIAL RELEASE	6/26/2018	Ruggiero
B			REPLACED FIBER PLUG WITH DELRIN SLEEVE	9/26/2018	richadmin
C			ADDED FIBER LENGTH TABLE SPECIFIED DELRIN FIBER SLEEVE TO BE BLACK UPDATED ASSEMBLY WITH NEW FIBER PLUG	8/2/2019	E.K.

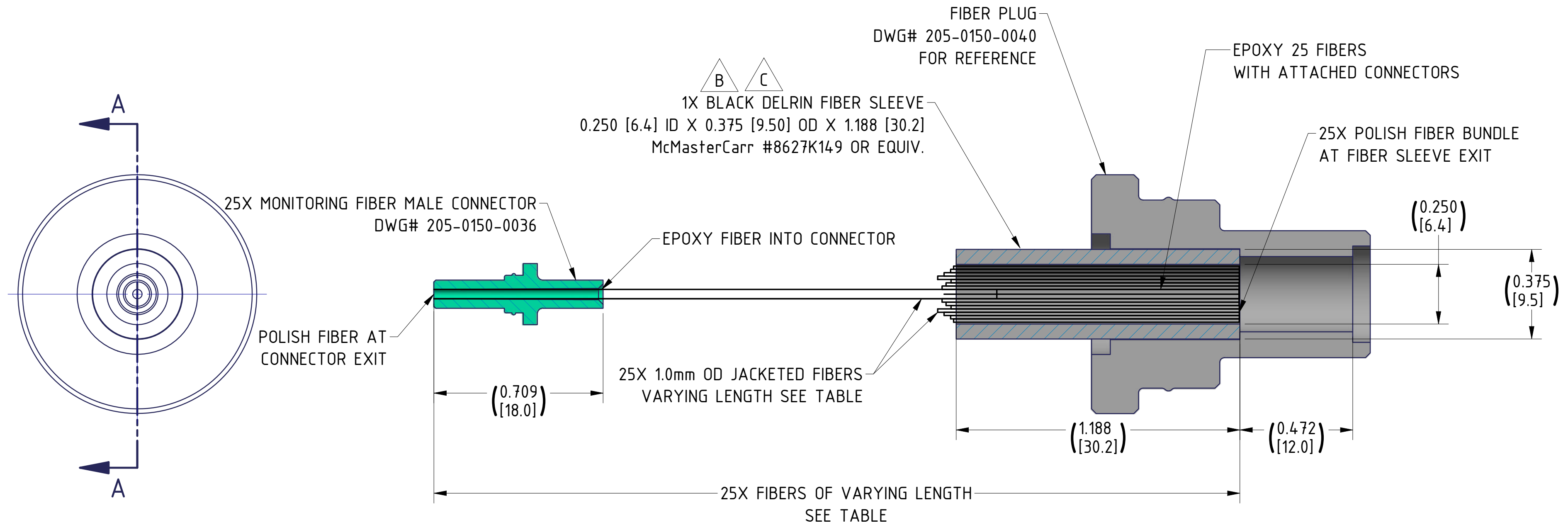

△ C

FIBER LENGTHS +/- 0.125 [3.2]		
FIBER #	QUANTITY	LENGTH
1	2	26.38 [670.0]
2	2	33.86 [860.0]
3	2	33.86 [860.0]
4	2	41.34 [1050.0]
5	2	53.98 [1370.0]
6	2	61.42 [1560.0]
7	2	72.83 [1850.0]
8	2	82.28 [2090.0]
9	2	93.70 [2380.0]
10	2	106.30 [2700.0]
11	2	119.29 [3030.0]
12	2	131.10 [3330.0]
13 (SPARE)	1	131.10 [3330.0]

CHECKING PRINT 8/2/2019

<p>THIRD ANGLE PROJECTION</p>				<p>BROOKHAVEN NATIONAL LABORATORY BROOKHAVEN SCIENCE ASSOCIATES UPTON, NY 11973</p>	
<p>INTERPRET IN GENERAL ACCORDANCE WITH ASME Y14.5-2009 UNLESS OTHERWISE SPECIFIED: ALL DIMENSIONS ARE IN INCHES [mm]</p> <p>DECIMAL TOLERANCES X.X ± 0.05 X.XX ± 0.01 X.XXX ± 0.005 ANGLES ± 0.5</p>		<p>DRAWN BY: R. RUGGIERO 6/26/2018</p> <p>CHECKED BY: C. PONTIERI 6/26/2018</p> <p>ENGINEER APPROVAL: J. HILLS 6/26/2018</p> <p>SUPERVISOR APPROVAL: D. LYNCH 6/26/2018</p> <p>DESIGN APPROVAL: E. KISTENEV 6/26/2018</p> <p>D.A. APPROVAL: C. GORTAKOWSKI 6/26/2018</p> <p>SAFETY ENGINEER: A. FRANZ 6/26/2018</p>	<p>PROJECT: HCAL</p> <p>DESCRIPTION: Fiber Bundle Assembly</p> <p>SIZE: C</p> <p>DRAWING NUMBER: 205-0150-0037</p>		<p>REV: C</p>
<p>OUTSTANDING ECN NUMBERS</p>		<p>FINISH: <input checked="" type="checkbox"/> BREAK EDGES: MAX: 0.015 MIN: 0.005</p>	<p>Q.A. CATEGORY: A3 SCALE: 3 : 1 WEIGHT: N/A SHEET: 1 OF 1</p>		