

4

3

2

1

ITEM NO.	QTY	DESCRIPTION	MATERIAL, DWG.NO. OR PART NO.	REV
1	1	MOUNTING PLATE	25-2043015	
2	1	BUSHING	25-2043008	
3	1	RESTRAINING PAD ASSY	25-2043013	
4	1	LOCK NUT	25-2043009	
5	1	SPACER	25-2043017	
6	2	CLAMPING CHANNEL	25-2043016	

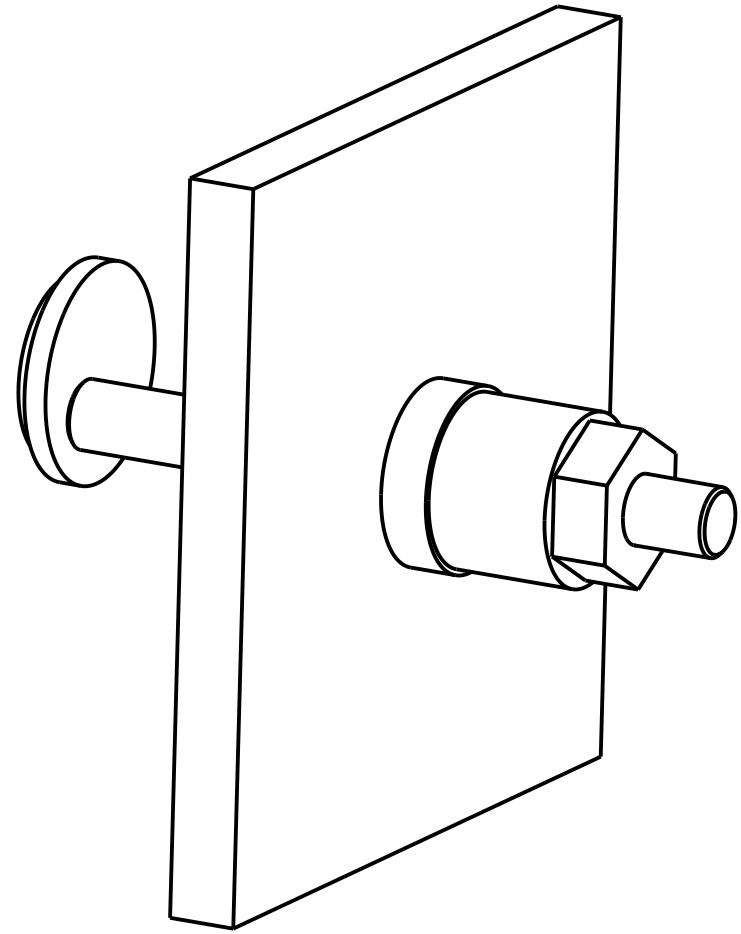

SCALE 1/2

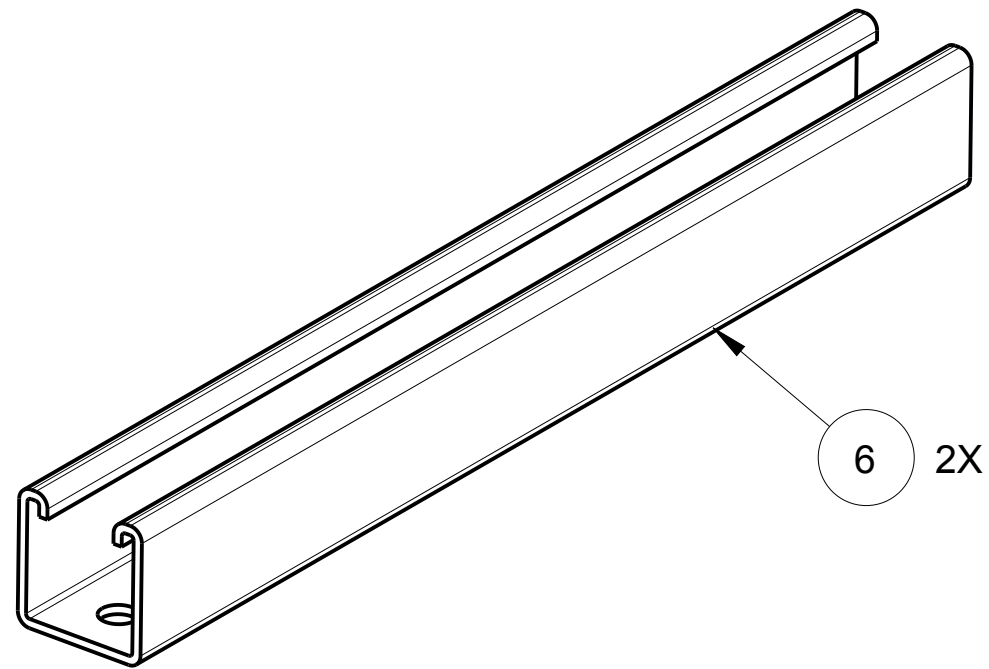

6 2X

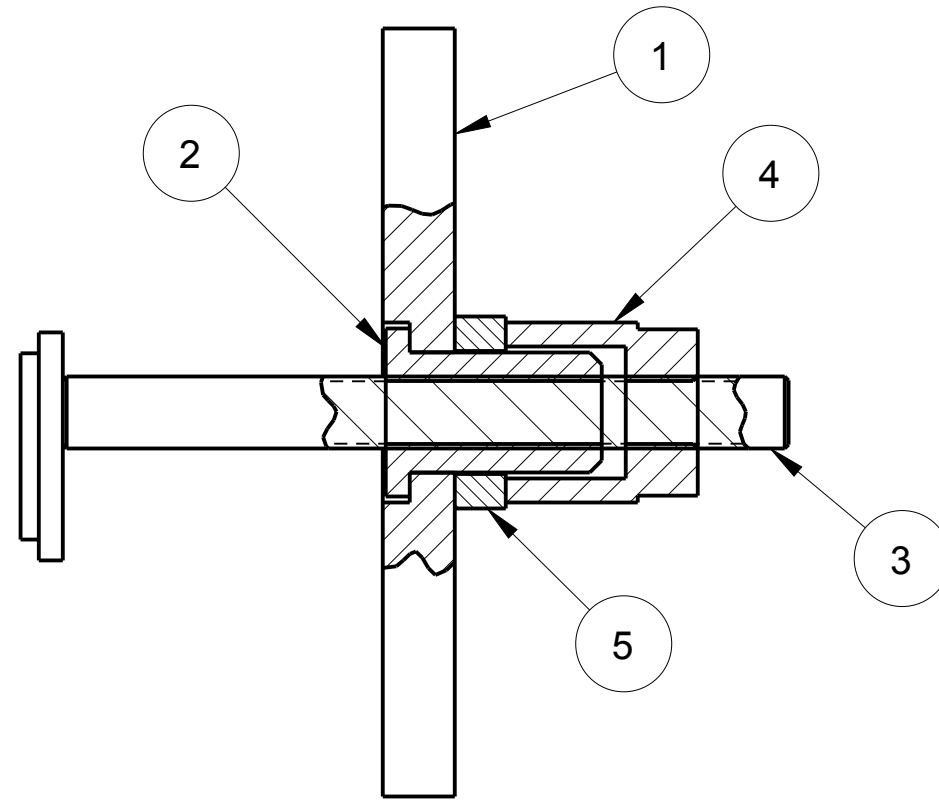

SECTION A-A

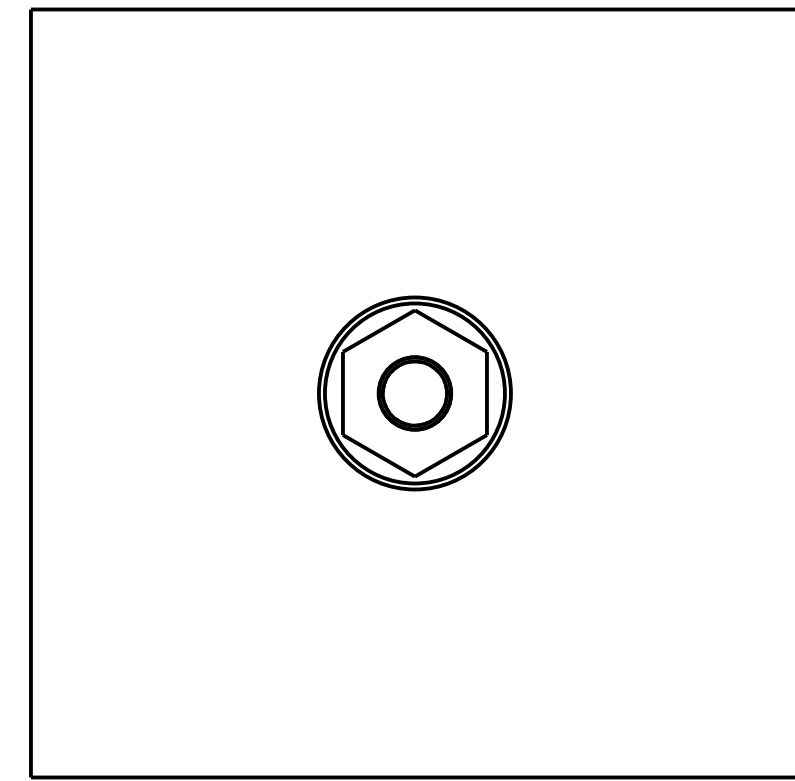

SCALE 1/2

REV	DESCRIPTION	BY	DATE	CKR	APP
B	REVISED AND REDRAWN	PEK	8-3-14		
A	INITIAL DWG RELEASE	PEK	4-18-14		

INTERPRET IN GENERAL ACCORDANCE WITH ASME Y14.24 UNLESS OTHERWISE SPECIFIED		<b>SUPERCONDUCTING MAGNET DIVISION</b>		<b>BROOKHAVEN NATIONAL LABORATORY</b> BROOKHAVEN SCIENCE ASSOCIATES UPTON, N.Y. 11973	
DIMENSIONS ARE IN INCHES DECIMAL TOLERANCES .X ± .06 .XX ± .02 .XXX ± .005 ANGULAR TOLERANCE ± 1°		DRAWN BY <b>P KOVACH</b> 8-3-2014	CHECKED BY <b>P KOVACH</b> 8-3-2014	TITLE: <b>BABAR MAGNET HEAT SHIELD SHIPPING RESTRAINT ASSY</b>	
<input checked="" type="checkbox"/> FINISH <input type="checkbox"/> BREAK SHARP EDGES		ENGINEER APPROVAL <b>MDA</b> 8-4-2014	SUPERVISOR APPROVAL <b>MDA</b> 8-4-2014	SIZE <b>C</b>	DRAWING NUMBER: <b>25- 2043001</b>
				MATERIAL: SEE B/M	SCALE: NOTED
				WEIGHT:	SHEET 1 of 1

4

3

2

1