

ITEM NO.	QTY	DESCRIPTION	MATERIAL, DWG.NO. OR PART NO.	REV
1	1	RESTRAINING PAD	25-2043014	
2	1	RESTRAINING STUD	25-2043012	

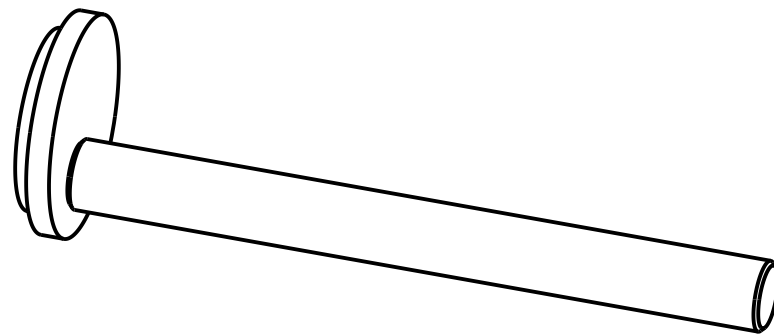

SCALE 1/2

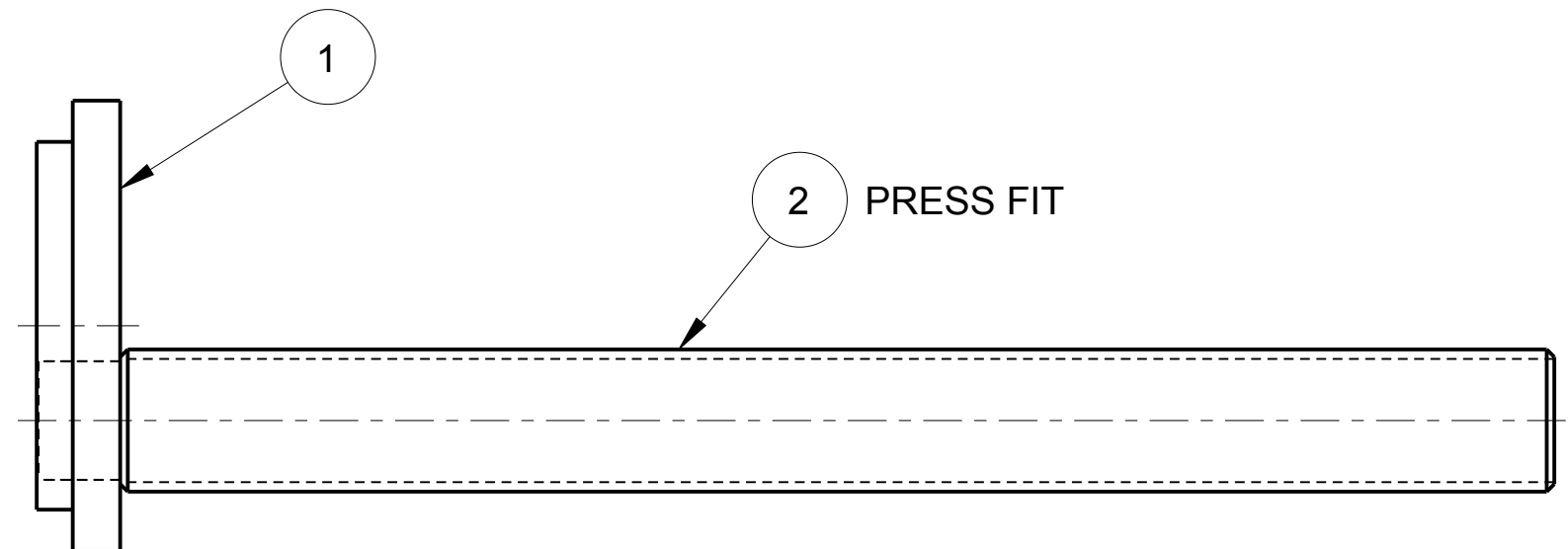
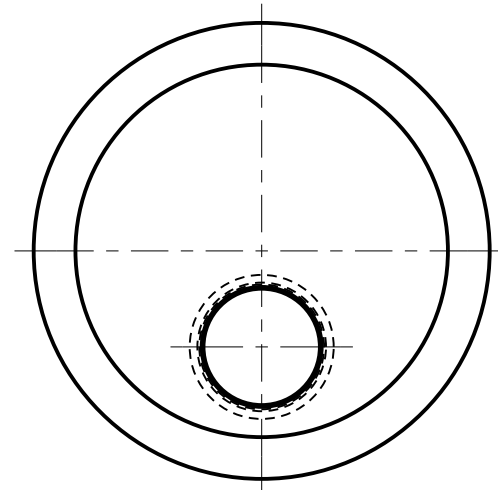

SCALE 1/1

INTERPRET IN GENERAL ACCORDANCE WITH ASME Y14.24 UNLESS OTHERWISE SPECIFIED		SUPERCONDUCTING MAGNET DIVISION		BROOKHAVEN NATIONAL LABORATORY BROOKHAVEN SCIENCE ASSOCIATES UPTON, N.Y. 11973		
DIMENSIONS ARE IN INCHES DECIMAL TOLERANCES .X± .06 .XX± .02 .XXX± .005 ANGULAR TOLERANCE ± 1°		DRAWN BY P KOVACH	8-3-2014	TITLE: BABAR MAGNET HEAT SHIELD SHIPPING RESTRAINT RESTRAINING PAD ASSEMBLY		
BREAK SHARP EDGES MAX. MIN.		CHECKED BY P KOVACH	8-3-2014			
<input checked="" type="checkbox"/> FINISH	<input type="checkbox"/>	ENGINEER APPROVAL MDA	8-4-2014			
		SUPERVISOR APPROVAL MDA	8-4-2014			
				SIZE B	DRAWING NUMBER: 25- 2043013	REV. A
				MATERIAL: SEE B/M	SCALE: NOTED	WEIGHT:
				SHEET 1 OF 1		

REV	DESCRIPTION	BY	DATE	CKR	APP
A	INITIAL DWG RELEASE	PEK	8-3-14		