

REVISION HISTORY					
REV	ECN NUMBER	ZONE	DESCRIPTION	DATE	APPROVED

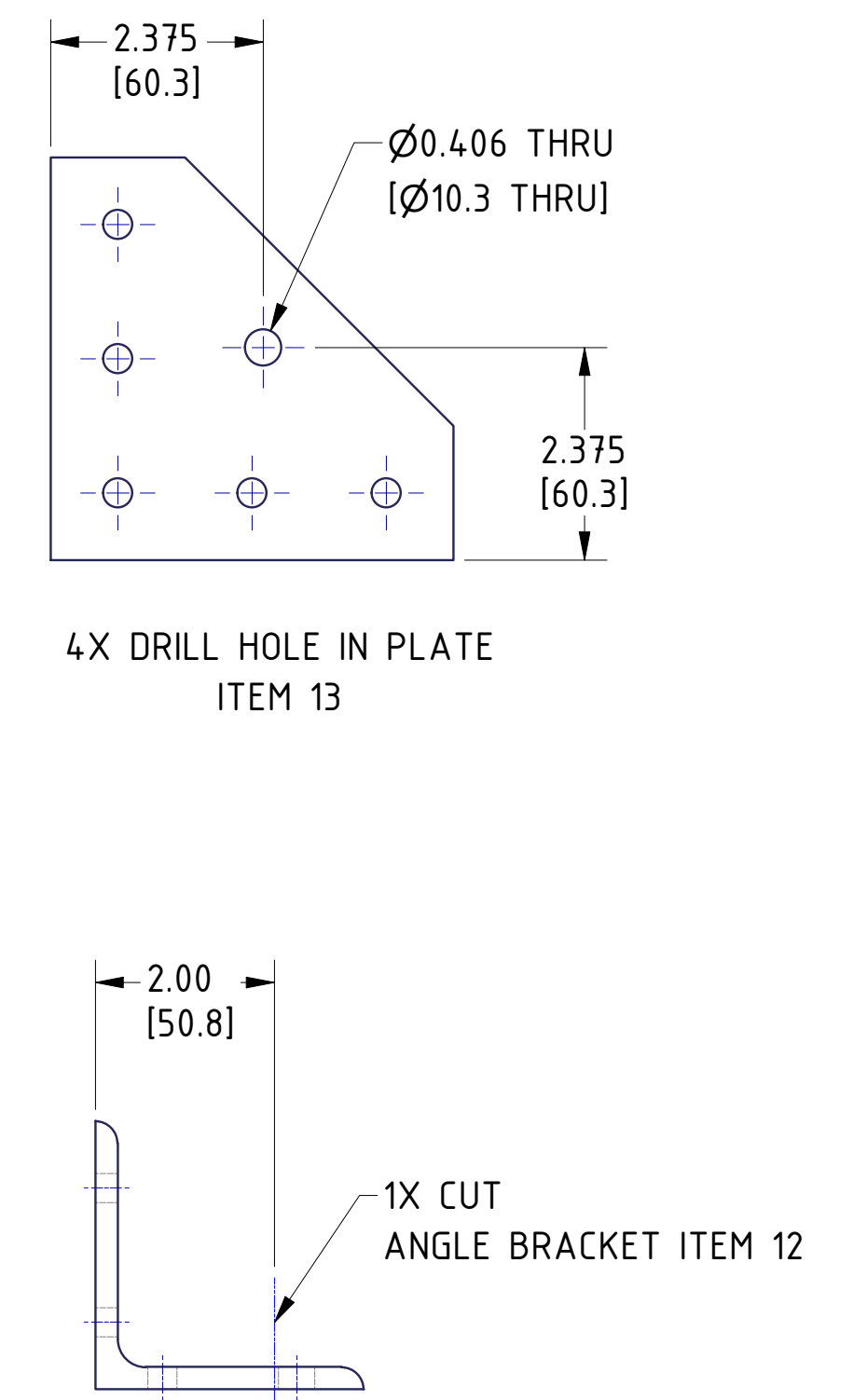

CHECKING PRINT
3/15/2023

SECTION A-A
SCALE 0.17

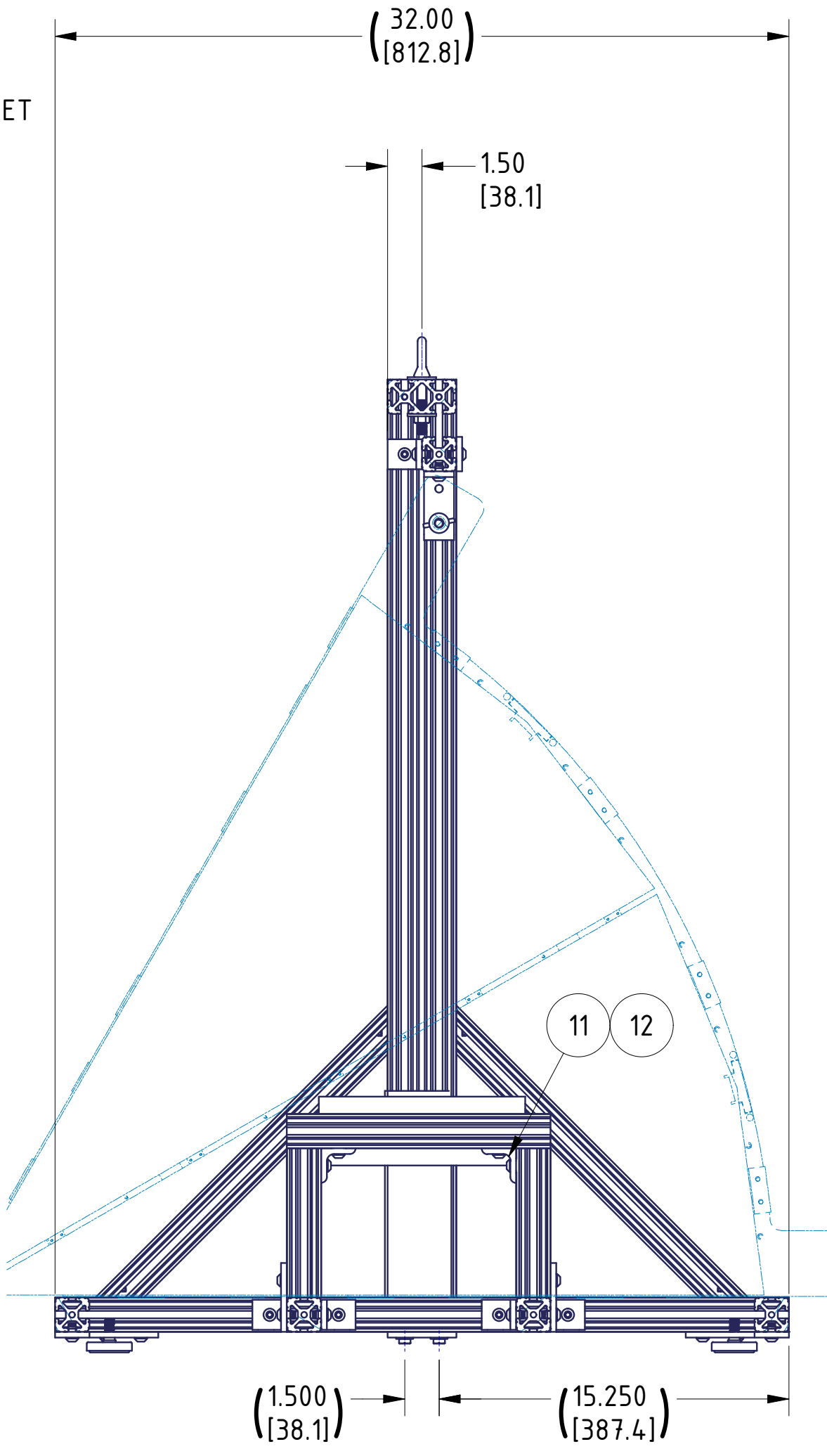
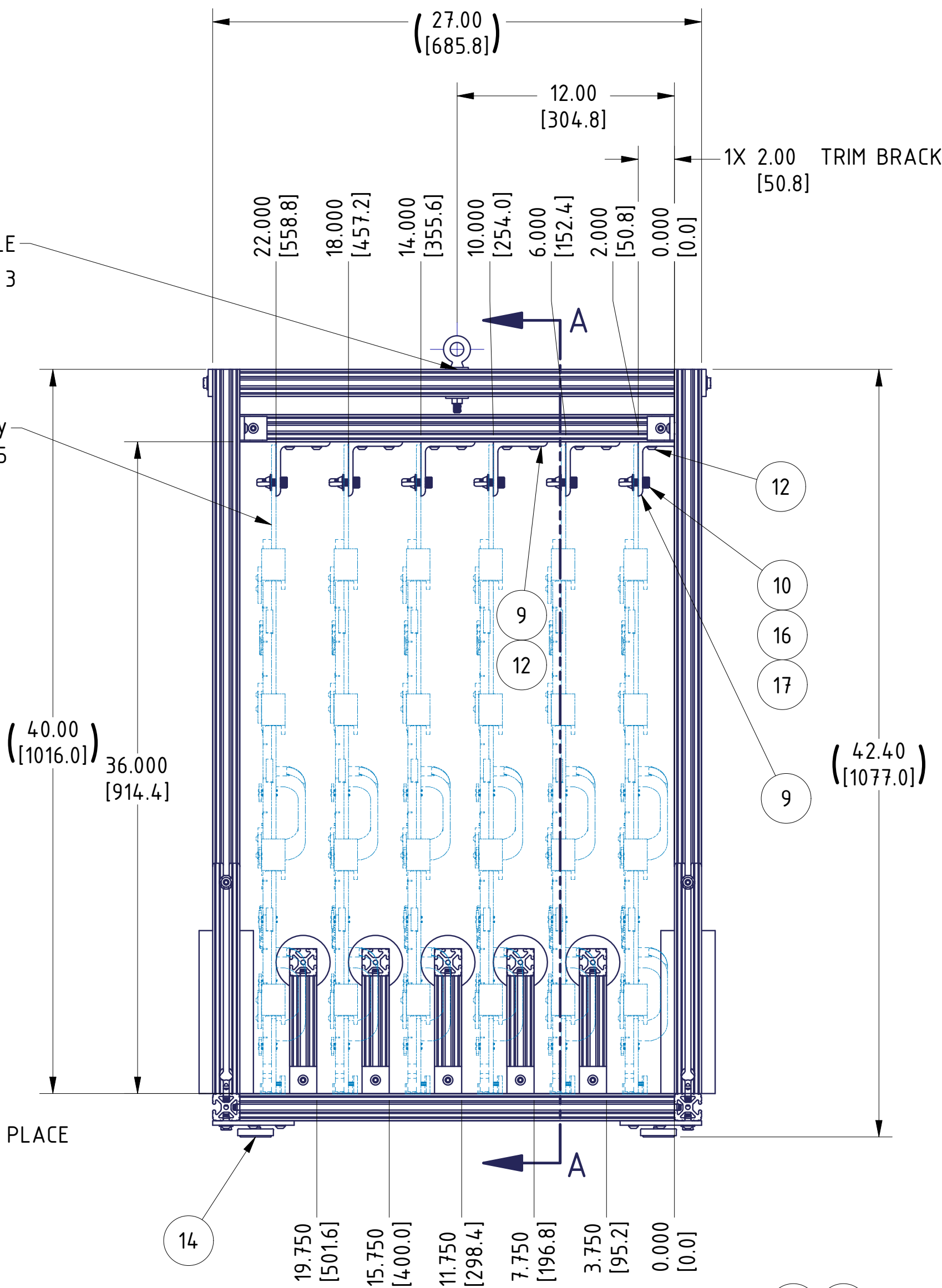
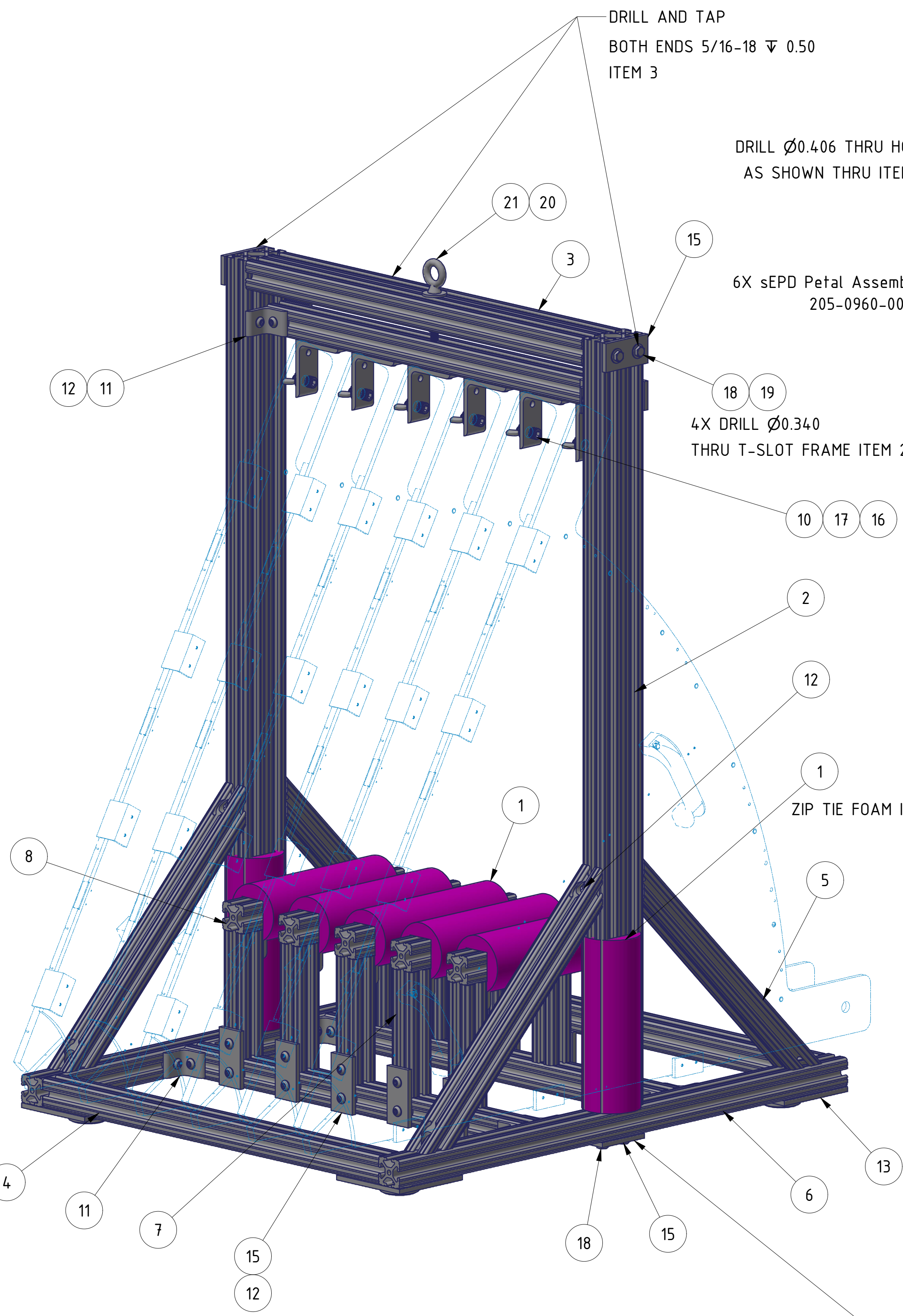
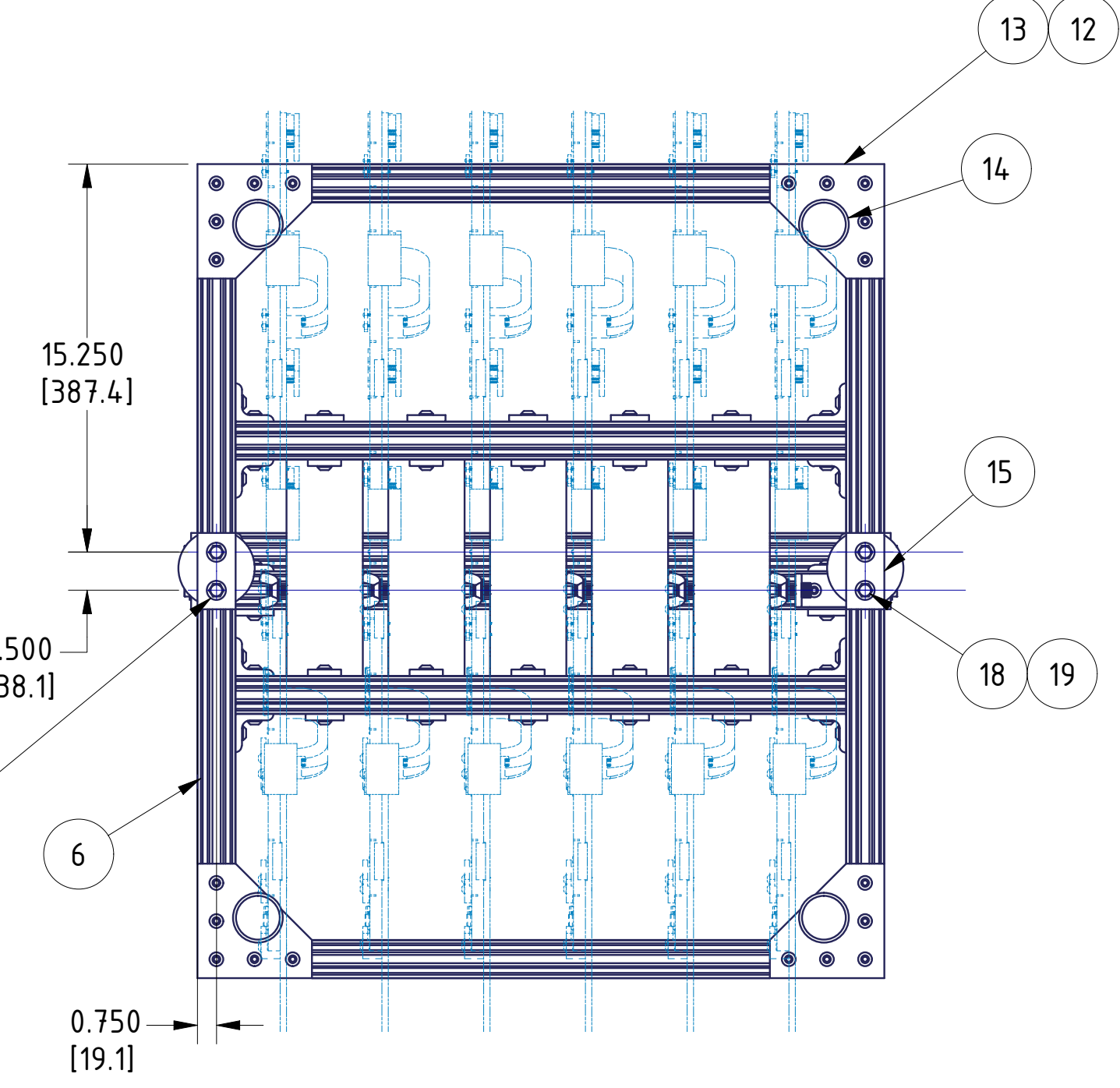

QTY	ITEM	PART NUMBER	DESCRIPTION
1	21	McMaster-Carr #3018T16 or Equiv.	Galvanized Steel Eyebolt with Nut and with Shoulder 1200 lbs CAP.
2	20	McMaster-Carr #92217A529 or Equiv.	3/8" Oversize Washer
8	19	McMaster-Carr #9214A030 or Equiv.	18-8 Stainless Steel Washer
8	18	McMaster-Carr #92198A691 or Equiv.	18-8 Stainless Steel Hex Head Screw
6	17	McMaster-Carr #90866A140 or Equiv.	Zinc-Plated Steel Wing Nut 3/8-16
6	16	McMaster-Carr #9214A030r Equiv.	18-8 Stainless Steel Washer 3/8
16	15	McMaster-Carr #47065T256 or Equiv.	T-Slotted Framing Silver Flat Bracket
4	14	McMaster-Carr #83685T13 or Equiv.	Corrosion-Resistant Swivel Leveling Mount
4	13	McMaster-Carr #47065T271 or Equiv.	T-Slotted Framing Silver Flat Corner Bracket
104	12	McMaster-Carr #47065T215 or Equiv.	T-Slotted Framing
20	11	McMaster-Carr #47065T845 or Equiv.	Silver Corner Bracket
6	10	McMaster-Carr #92196A624 or Equiv.	18-8 Stainless Steel Socket Head Screw
6	9	McMaster-Carr #47065T241 or Equiv.	Silver Corner Bracket
5	8	McMaster-Carr #47065T127 or Equiv. (48in)	T-Slotted Framing - 11.5in
10	7	McMaster-Carr #47065T127 or Equiv. (48in)	T-Slotted Framing - 6.5in
2	6	McMaster-Carr #47065T127 or Equiv. (48in)	T-Slotted Framing - 32in
4	5	McMaster-Carr #47065T702 or Equiv.	T-Slotted Framing 18in x 45deg
5	4	McMaster-Carr #47065T127 or Equiv. (48in)	T-Slotted Framing - 24in
1	3	McMaster-Carr #47065T137 or Equiv. (48in)	T-Slotted Framing - 24in 15 x 3.0
2	2	McMaster-Carr #47065T137 or Equiv. (48in)	T-Slotted Framing - 40in 15 x 3.0
7	1	McMaster-Carr #4530K168 or Equiv. (72in)	Insulating Foam Bumper

BILL OF MATERIALS

<p>THIRD ANGLE PROJECTION</p> <p>INTERPRET IN GENERAL ACCORDANCE WITH ASME Y14.5-2009 UNLESS OTHERWISE SPECIFIED. ALL DIMENSIONS ARE IN INCHES (mm)</p> <p>DECIMAL TOLERANCES X.XX ± 0.05 X.XXX ± 0.01 X.XXXX ± 0.005 ANGLES ± 0.5</p>		BROOKHAVEN NATIONAL LABORATORY BROOKHAVEN SCIENCE ASSOCIATES UPTON, NY 11973	
		sEPD Petal Carrier	
		205-0960-0030	
		REV: A	

OUTSTANDING ECN NUMBERS	250 / FINISH	BREAK EDGES: MAX. ± 0.05, MIN. ± 0.005	SAFETY ENGINEER	D.A. CATEGORY: A3	SCALE: 0.17	WEIGHT: N/A	SHEET: 1 OF 1
-------------------------	--------------	--	-----------------	-------------------	-------------	-------------	---------------