

M A T E R I A L S	BODY	BRASS NICKEL PLATED
	CONTACT	GOLD PLATED
	INSULATOR	PTFE
	GASKET	RUBBER

E L E C T R I C A L	IMPEDANCE	50 OHMS
	FREQUENCY RANGE	DC - 300 MHz
	OPERATING VOLTAGE	3,500 VOLTS RMS 5,000 VOLTS DC

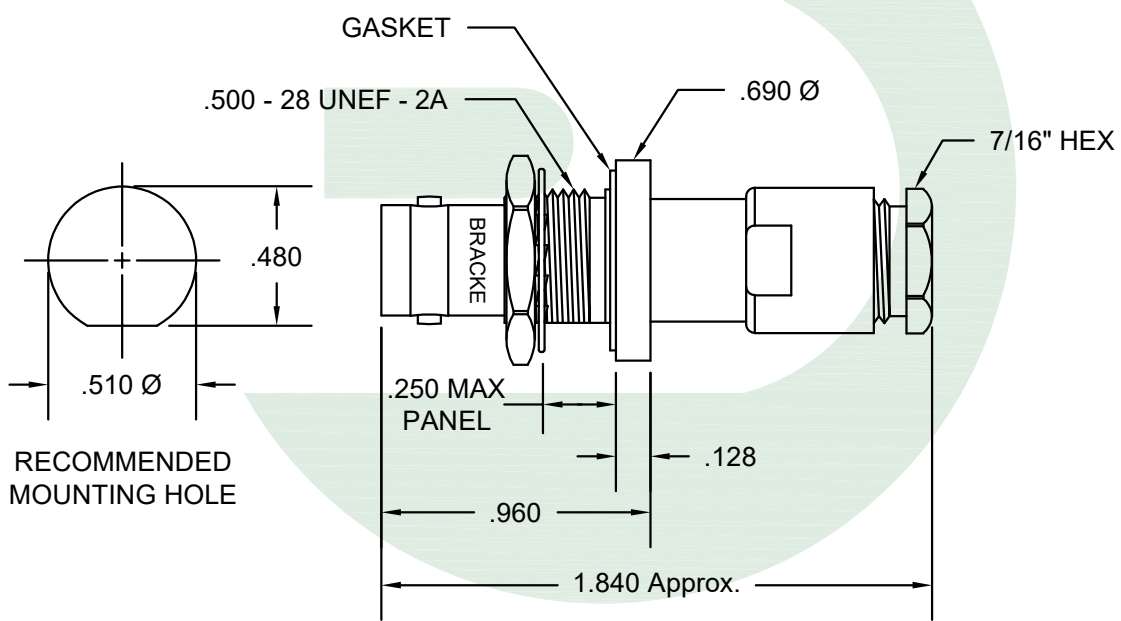

RECOMMENDED MOUNTING HOLE

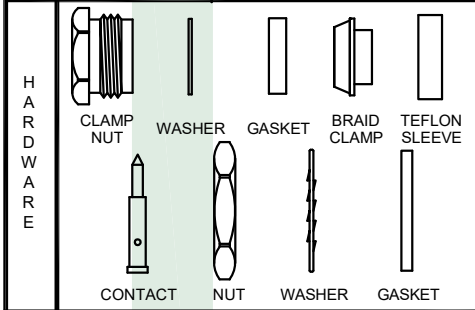
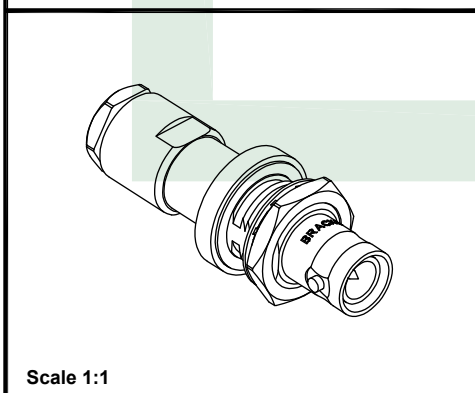

Scale 1:1



BRACKE
Bracke Manufacturing, LLC

Bracke Manufacturing, LLC
PO Box 12319
Newport Beach, Ca 92658
Phone (949)756-1600 / Fax (949) 756-1601
sales@brackemfg.com / www.brackemfg.com

Part Number	
BM60353	
Produced By	Checked By
002	013

Description
SHV Jack Bulkhead
50 Ohm, Clamp Connector [RG174, RG188, RG316]

Notes

- Bracke Manufacturing, LLC reserves the right to change any specifications at any time in its sole discretion without notice.
- The depiction above was produced by and is the sole property of Bracke Manufacturing, LLC and may not be copied or reproduced in any manner without Bracke's prior written consent.

©2020 Bracke Manufacturing, LLC

CAGE / NAGE	
6LOW2	
Scale	Unit
1.5:1	Inches
Date	Revision
5/28/2020	A-01

ASSEMBLY

- 1- STRIP CABLE AS SHOWN
- 2- SLIDE HARDWARE ON CABLE
- 3- FORM BRAID WIRES OVER CLAMP AND CUT EXCESS AT SHOULDER
- 4- SLIDE TEFLON SLEEVE OVER DIELECTRIC
- 5- INSERT CENTER CONDUCTOR INTO CONTACT
6- SOLDER CONTACT TO CENTER CONDUCTOR
- 7- INSERT SUBASSEMBLY INTO BODY
8- TIGHTEN CONNECTOR USING 7/16\"/>
- 9- INSTALL HARDWARE ON CONNECTOR